

CATALOGO DE REPUESTOS

XV535(4YHB)ESPAÑA

YAMAHA
GENUINE
Parts & Accessories

104YH-352S1

2005/12/26

NEWS No.	DATE	COMMENT
PE0-MC-040084	Aug., 06, 2004	FIG.35: FLASHER LIGHT LIST&ILLUSTRATION REVISION

A2

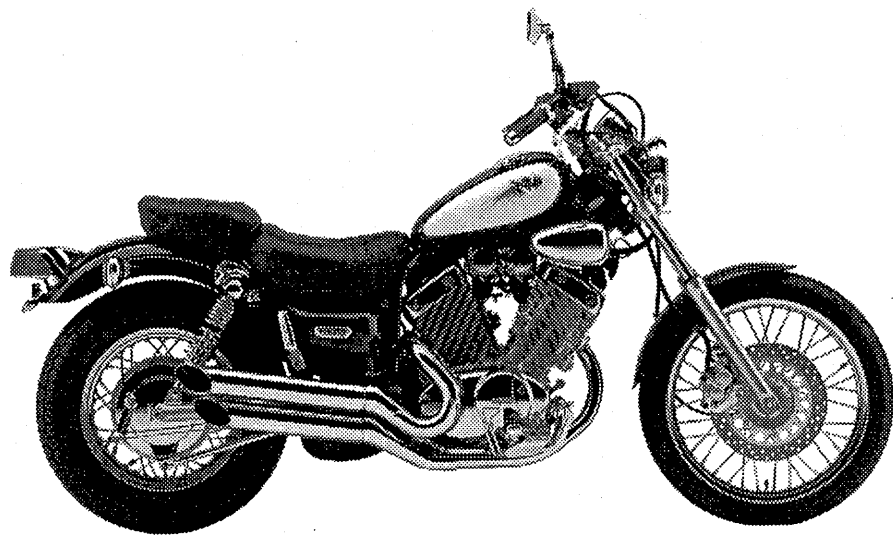

A3

PROLOGO

Este Catálogo de Repuestos corresponde a las piezas para el(los) modelo(s) del recuadro siguiente. Al formular el pedido de repuestos, se ruega citar este Catálogo de Repuestos y especificar correctamente los números de parte y los nombres de parte.

XV535(4YHB)

1. Las modificaciones y agregados que se hayan realizado después de la edición de este Catálogo de Repuestos, serán anunciados en las Informaciones de Recambios Yamaha.

2. Abreviaciones

En este Catálogo de Repuestos se emplean las siguientes abreviaciones.

"UR" Usar el número de partes especificado

"UN" Usar la cantidad necesaria

"AP" Piezas sustitutivas

"LM" Fabricación local (Partes necesarias que se pedirán localmente)

"F#" No. de bastidor aplicable

3. Las piezas suministradas como conjunto se describen con un punto (.) que precede al nombre de la pieza como se indica a continuación.

EJEMPLO

CONJUNTO CARBURADOR

.INYECTOR, piloto

.BOQUILLA, principal

4. Cantidad de componentes de un conjunto

La numeración que aparece a la derecha de cada descripción, indica la cantidad de piezas por cada unidad de conjunto.

EJEMPLO

PIEZAS NO.	DESCRIPCION	CANT.	OBSERVACION
2F5-83310-60	ENSAMBLAJE DE LA LUZ	2	
115-83311-60	.BOMBILLA (6V-1 8W)	1	
1M1-83309-60	.REFLECTOR	1	

5. Los colores de los componentes se indican como sigue en la columna de "OBSERVACIONES".

EJEMPLO

PIEZAS NO.	DESCRIPCION	CANT.	OBSERVACION
2N4-24110-00-X5	.COMP. DEL TANQUE	2	MXR
3J1-24240-10	.GRAFICO, DEL TANQUE	1	para MXR

6. Números de Serie

No. de Serie del motor.

No. de Serie del bastidor

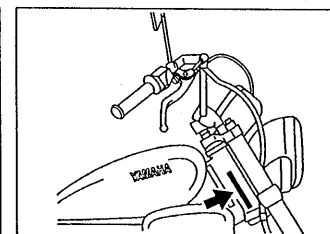
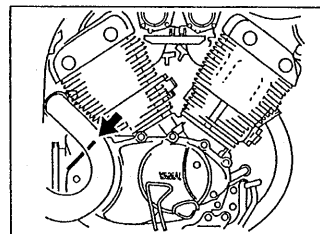

7. Debe tenerse en cuenta que las ilustraciones sirven como guía para la búsqueda de las referencias y no deben usarse para el montaje. Durante el montaje, se recomienda usar el manual de Taller correspondiente.

8. EL asterisco (*) antes del número de referencia indica los elementos modificados después de la primera edición.

ROTULO DE MODELO

(1) El rótulo llamada "Rótulo de Modelo" está en la ubicación indicada abajo en el (3). Cuando se utilice este catálogo de partes, se ruega cotejar entre el "código de modelo-número de código de producción" del catálogo y el "código de modelo-número de código de producción" indicado en el Rótulo de Modelo fijado en el producto correspondiente.

(2) Indicación del "Rótulo de Modelo"

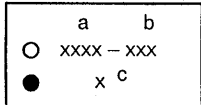

a: Código de tipo de Modelo

b: Número de código de Producción

c: Tipo de color

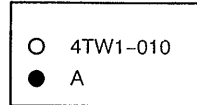

(3) Ubicación de fijación del Rótulo de Modelo

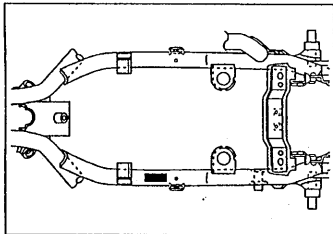

(4) Código de Modero-Número de código de Producción del Modelo Listado en este Catálogo de Partes

Código de Modelo	Número de Código de Producción	Pais(destine)	Código de Modelo	Número de Código de Producción	Pais(destine)
4YHB	050	ESPAÑA			

(5) Información de Color

Código de Modelo	Código de tipo de color	Código de color	Nombre de color	Abreviatura
4YHB	A	00JW	URUSHI BLACK	URB
	B	0679	DARK CYAN METALLIC 8	DCM8
	C	0646	DULL YELLOWISH RED METALLIC 2	DYRM2

CONTENIDO

MOTOR

CULATA DE CILINDRO	B2
CILINDRO	B4
CIGUENAL. PISTON	B5
VALVULA	B6
ARBOL DE LEV. CADENA	B7
BOMBA DE ACEITE	B8
FILTRO ACEITE	B9
ADMISION	B10
CARBURADOR	B12
DESCARGA	B15
CARTER	C2
CUBIERTA DE CARTER 1	C4
EMBRAG. DEL ARRANQUE	C6
EMBRAGUE	C7
TRANSMISION	C9
ENGR. MEDIO DE TRAC.	C10
LEVA DE CAMBIO. HORQ	C11
EJE DE CAMBIO. PEDAL	C12

SHASIS

CUADRO	C13
GUARDABARRO	C15
CUBIERTA LATERAL	D3
BRAZO TRASERO. SUSPENSION	D4
EJE DE TRACCION	D5
DIRECCION	D7
HORQUILLA DELANTERA	D9
DEPOSITO DE COMBUSTIBLE	D11
ASIENTO	D14
RUEDA DELANTERA	D15
CALIBRE FRENO DELANTERA	E2
RUEDA TRASERA	E3

MANUBRIO. CABLE	E5
CILINDRO MAESTRO DELANTERO	E6
SOPORTE. APOYAPIE	E7
GENERADOR	E10
LUZ DE DESTELLADOR	E11
MEDIDOR	E12
FARO DELANTERO	E13
LUZ DE COLA	E14
INTERRUPTOR DE MANIJA. PALANCA	E15
EQUIPO ELECTRICO 1	F2
EQUIPO ELECTRICO 2	F3

INDICE

NUMERICAL INDEX	M1
-----------------------	----

FIG. 1 CULATA DE CILINDRO

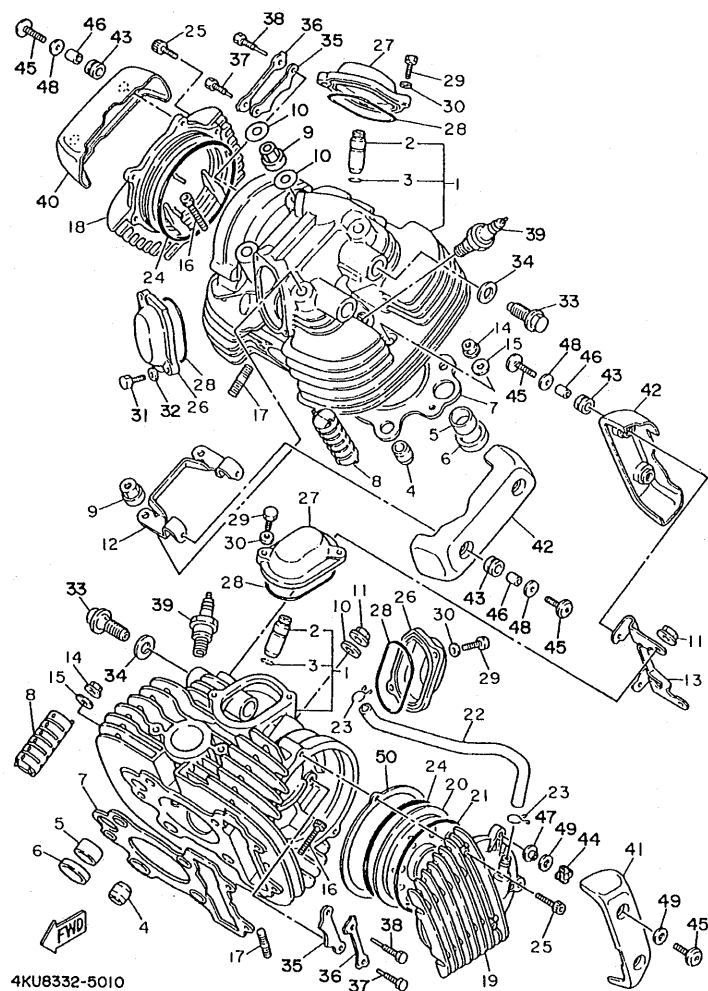

REF. NO.	CODIGO NO.	DESCRIPCION	4YHB			OBSERVACION
1	2GV-11102-02	CULATA DE CILINDRO COMPLETA	2			
2	4H7-11133-10	.GUIA VALV.DE ADM.	2			
3	93440-12052	.BOLA	2			
4	99530-17016	PASADOR, DE ESPIGA	4			
5	90387-226G7	CASQUILLO CON VALONA	2			
6	90430-24184	JUNTA	2			
7	2GV-11181-00	JUNTA, DE CULATA 1	2			
8	2GV-11127-00	AMORTIGUADOR 3	4			
9	90179-10395	TUERCA	4			
10	90201-10131	ARANDELA PLANA	4			
11	90179-10279	TUERCA	4			
12	2GV-11142-00	SOPORTE DE CULATA DE CINDRO CU	1			
13	2GV-11152-00	SOPORTE DE CULATA DE CINDRO CU	1			
14	95707-08500	TUERCA DE BRIDA	2			
15	90201-08366	ARANDELA PLANA	2			
16	91314-08030	PERNO	4			
17	95617-08630	PERNO DE PUNTAL	4			
18	2GV-11185-00	CUBIERTA CULATA CIL.LAT.1	1			
19	2GV-1111H-00	CUBIERTA LATERALE DE CULATA 4	1			
20	22U-11165-00	PLACA RESPIRADERO	1			
21	93210-89568	ANILLO O	1			
22	2GV-11166-00	TUBO RESPIRADERO 1	1			
23	90467-14015	PRESILLA	2			
24	93211-00612	ANILLO O	2			
25	91314-06025	PERNO	4			
26	22U-11186-00	CUBIERTA CULATA CIL.LAT.2	2			
27	22U-11187-00	CUBIERTA CULATA CIL.LAT.3	2			

FIG. 1 CULATA DE CILINDRO

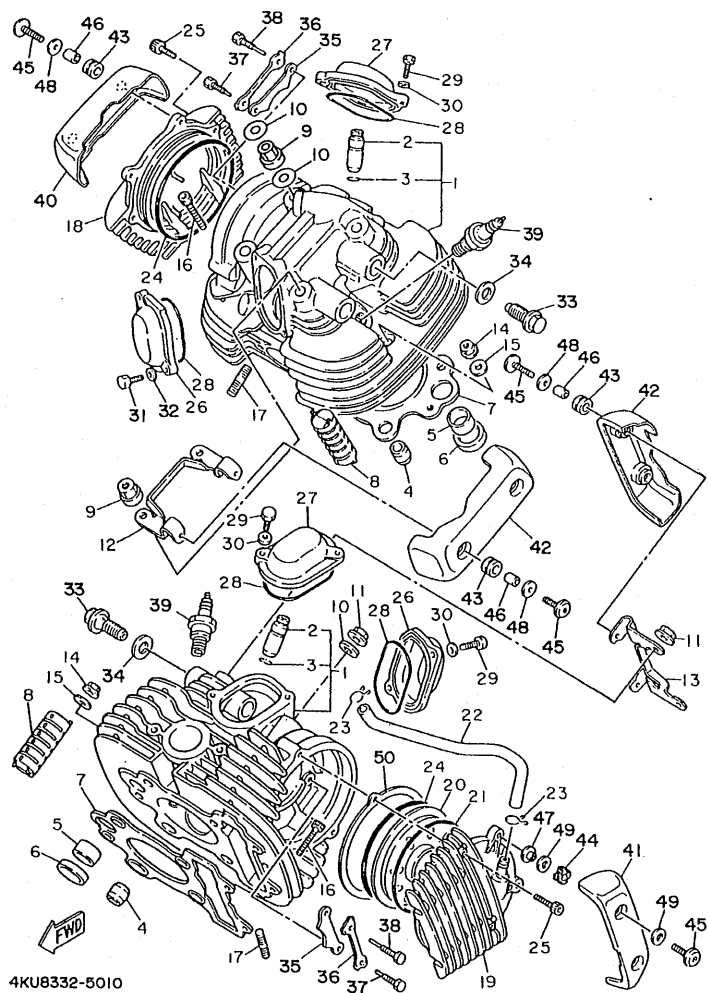

4KU8332-5010

REF. NO.	CODIGO NO.	DESCRIPCION	4YHB				OBSERVACION
28	93210-62446	ANILLO O	4				
29	97027-06016	PERNO	6				
30	92907-06600	ARANDELA	6				
31	97024-06016	PERNO	2				
32	92904-06600	ARANDELA	2				
33	90401-16166	PERNO DE UNION	4				
34	90430-17168	JUNTA	4				
35	22U-1111F-01	PLACA	2				
36	90215-08229	ARANDELA DE CIERRE	2				
37	90109-08782	PERNO	2				
38	90109-08781	PERNO	2				
39	94701-00234	BUJIA	2				UR
	94701-00228	BUJIA	2				UR
40	2NT-11186-01	CUBIERTA CULATA CIL.LAT.2	1				
41	2NT-1110M-01	CUBIERTA COMPLETO 1	1				
42	2NT-11187-01	CUBIERTA CULATA CIL.LAT.3	2				
43	90480-18411	TAPON	6				
44	90480-19471	TAPON	2				
45	90110-06198	TORNILLO ALLEN	8				
46	90387-06518	CASQUILLO CON VALONA	6				
47	90387-074T1	CASQUILLO CON VALONA	2				
48	90201-06071	ARANDELA PLANA	6				
49	3BT-11195-00	EMPAQUE	4				
50	3BT-11196-00	EMPAQUE DE CULATA	1				

FIG. 2 CILINDRO

REF. NO.	CODIGO NO.	DESCRIPCION	4YHB	OBSERVACION
1	2GV-11310-00	CILINDRO	1	
2	2GV-11320-00	CILINDRO 2	1	
3	93210-81411	ANILLO O	2	
4	15A-11162-00	AMORTIGUADOR 2	6	
5	91317-06085	PERNO	2	
6	3BT-11351-01	JUNTA, DE CILINDRO	2	

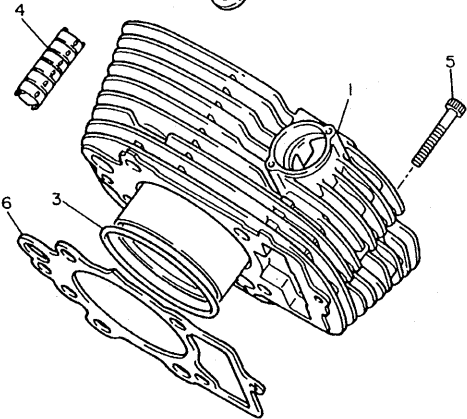
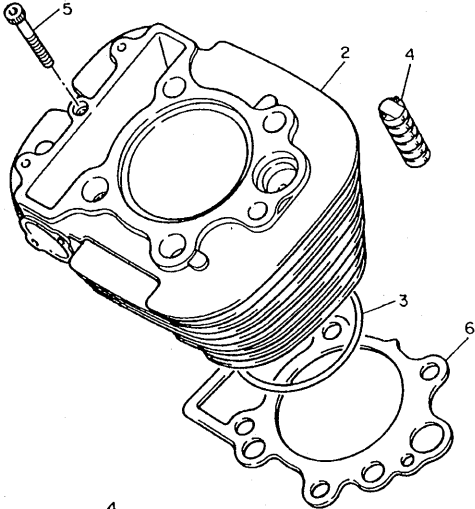

2GV110-7020

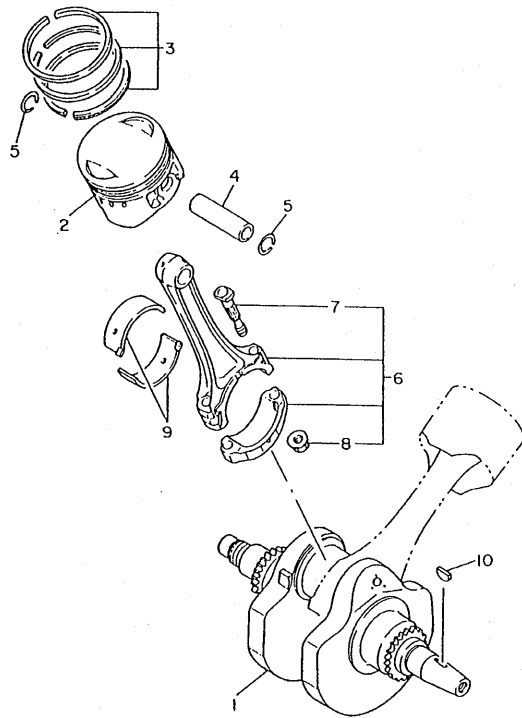

FIG. 3 CIGUENAL. PISTON

REF. NO.	CODIGO NO.	DESCRIPCION	4YHB				OBSERVACION
1	22U-11411-00	CIGUENAL	1				
2	2GV-11631-00-C0	PISTON(STD)	2				
	2GV-11636-00	PISTON (0.50MM O/S)	2				AP
	2GV-11638-00	PISTON (1.00MM O/S)	2				AP
3	2GV-11610-00	JUEGO DE AROS (NORMA)	2				
	2GV-11610-20	JUEGO DE AROS (0.50MM O/S)	2				AP
	2GV-11610-40	JUEGO DE AROS (1.00MM O/S)	2				AP
4	22U-11633-01	PASADOR, PISTON	2				
5	93450-19052	BOLA	4				
6	22U-11650-00	BIELA COMPLETA	2				
7	22U-11654-00	TORNILLO DE BIELA	2				
8	90179-08327	TUERCA	2				
9	22U-11656-00	COJINETE PLANO	4				UR
	22U-11656-10	COJINETE PLANO	4				UR
	22U-11656-20	COJINETE PLANO	4				UR
	22U-11656-30	COJINETE PLANO	4				UR
10	90280-05048	CUNA WOODRUFF	1				



2GV110-7030

FIG. 4 VALVULA

REF. NO.	CODIGO NO.	DESCRIPCION	4YHB			OBSERVACION
1	22U-12111-00	VALVULA DE ADMISION	2			
2	22U-12121-01	VALVULA DE ESCAPE	2			
3	3Y1-12116-00	ASIENTO RESORTE DE VALVULA	4			
4	22U-12113-00	RESORTE VALVULA INTERNA	4			
5	22U-12114-00	RESORTE VALVULA EXTERIOR	4			
6	1J7-12119-01	SELLO DE ACEITE VALVULA	4			
7	3Y1-12117-01	RETEN RESORTE DE VALVULA	4			
8	1J7-12118-00	SEGURO DE VALVULA	8			
9	22U-12151-00	BRAZO DE BALANCIN DE VALVULA	4			
10	22U-12156-01	EJE DE BALANCIN	4			
11	22U-12159-00	TORNILLO DE AJUSTE DE VALVULA	4			
12	90170-06128	TUERCA	4			

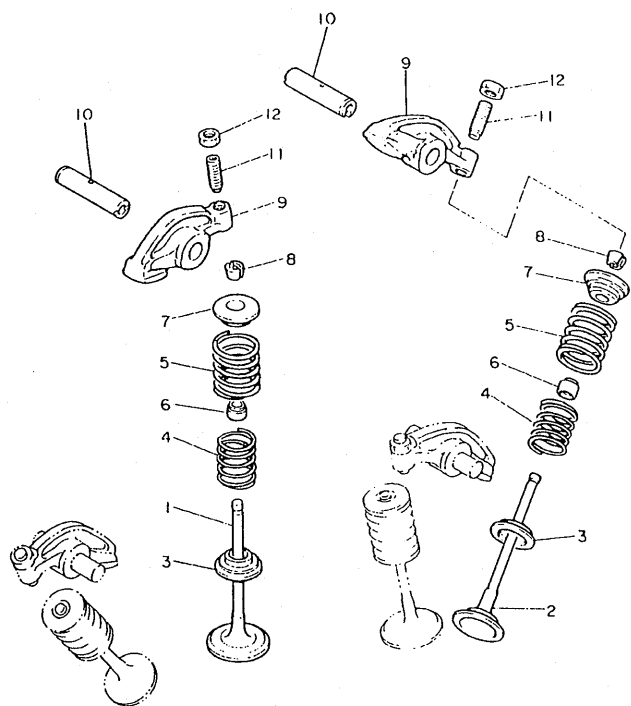

22U110-3050

FIG. 5 ARBOL DE LEV. CADENA

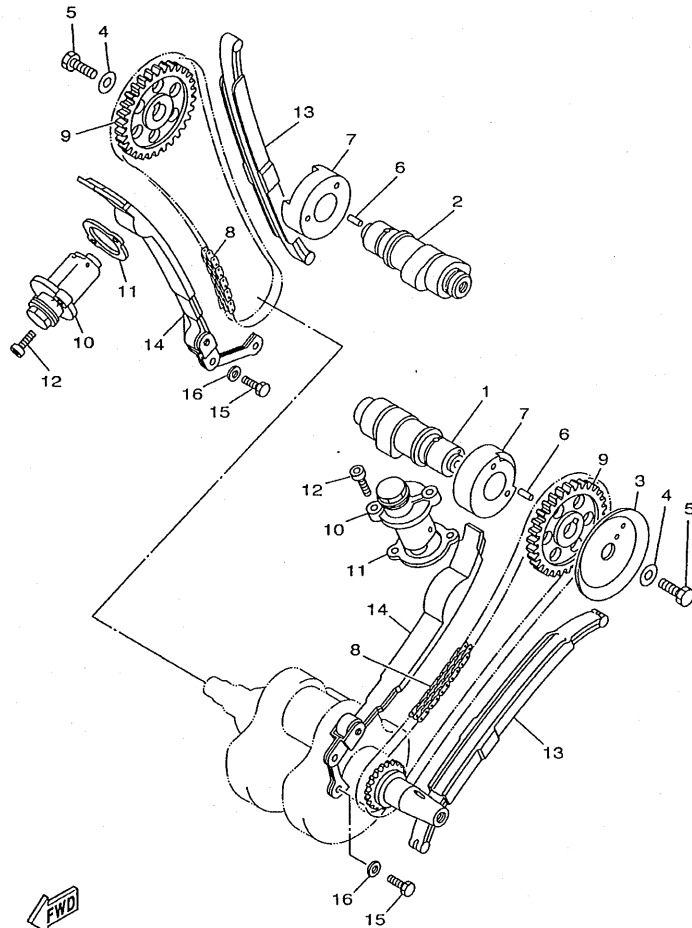

REF. NO.	CODIGO NO.	DESCRIPCION	4YHB			OBSERVACION
1	22U-12171-01	ARBOL DE LEVAS 1	1			
2	22U-12181-01	ARBOL DE LEVAS 2	1			
3	22U-11145-00	PLACA RESPIRADERO 2	1			
4	90201-10591	ARANDELA PLANA	2			
5	90101-10303	TORNILLO	2			
6	93605-10108	PASADOR DE CLAVIJA	2			
7	90380-28110	CASQUILLO SOLIDO	2			
8	94591-41118	CADENA	2			
9	22U-12176-01	CATALINA DE CADENA	2			
10	11H-12210-02	TENSOR CADENA DE LEVA	2			
11	3BT-12213-00	EMPAQUE DE CAJA TENSOR	2			
12	91314-06025	PERNO	4			
13	22U-12231-00	TOPE DE GUIA 1	2			
14	22U-12241-00	TOPE DE GUIA 2	2			
15	97027-06016	PERNO	4			
16	92907-06600	ARANDELA	4			



4VR1300-7050

FIG. 6 BOMBA DE ACEITE

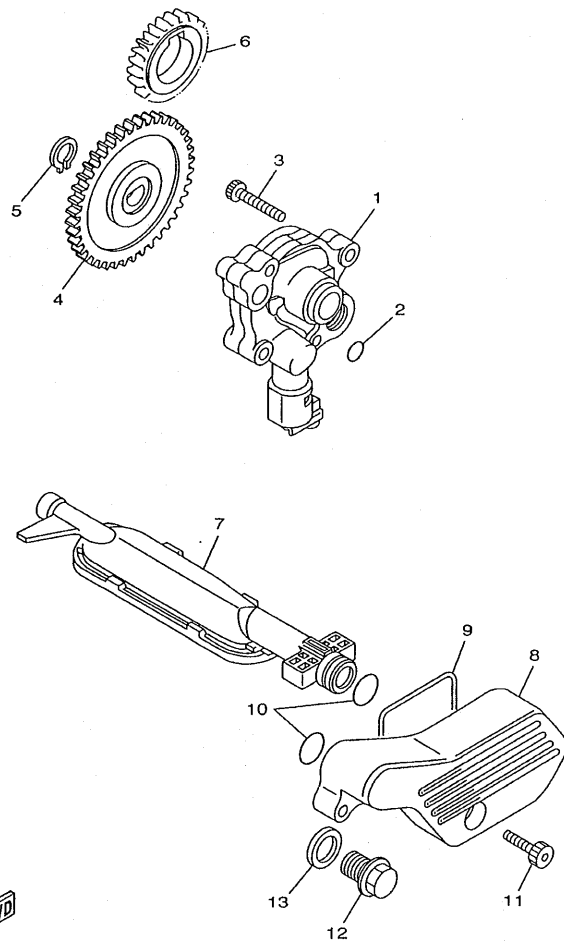



4YH7351-8060

REF. NO.	CODIGO NO.	DESCRIPCION	4YHB				OBSERVACION
1	22U-13300-00	BOMBA DE ACEITE COMPLETA	1				
2	93210-10096	ANILLO O	1				
3	91317-06030	PERNO	3				
4	4VR-13325-00	ENGRANAJE IMPULSOR DE BOMBA 1	1				
5	99009-11400	PRESILLA REDONDA	1				
6	22U-13324-00	ENGRANAJE TRACC. DE BOMBA	1				
7	22U-13410-00	CAJA DE FILTRO COMPLETA	1				
8	2GV-13417-00	TAPA DE FILTRO	1				
9	22U-13415-00	SELLO COLADOR ACEITE	1				
10	93210-15151	ANILLO O	2				
11	91317-06025	PERNO	3				
12	90340-14132	TORNILLO, DE DRENAJE	1				
13	214-11198-01	EMPAQUE	1				

FIG. 7 FILTRO ACEITE

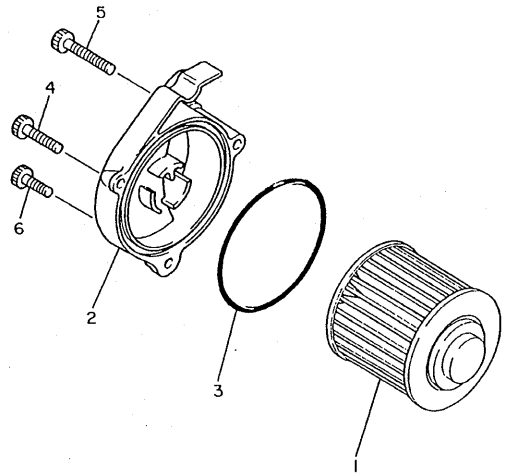
REF. NO.	CODIGO NO.	DESCRIPCION	4YHB				OBSERVACION
1	4X7-13440-01	ELEMENTO FILTRO DE ACEITE	1				
2	3JB-13447-00	TAPA DEL ELEMENTO	1				
3	93210-64297	ANILLO O	1				
4	91314-06060	PERNO	1				
5	91314-06095	PERNO	1				
6	91314-06025	PERNO	1				



2GV110-7070

B9

FIG. 8 ADMISION

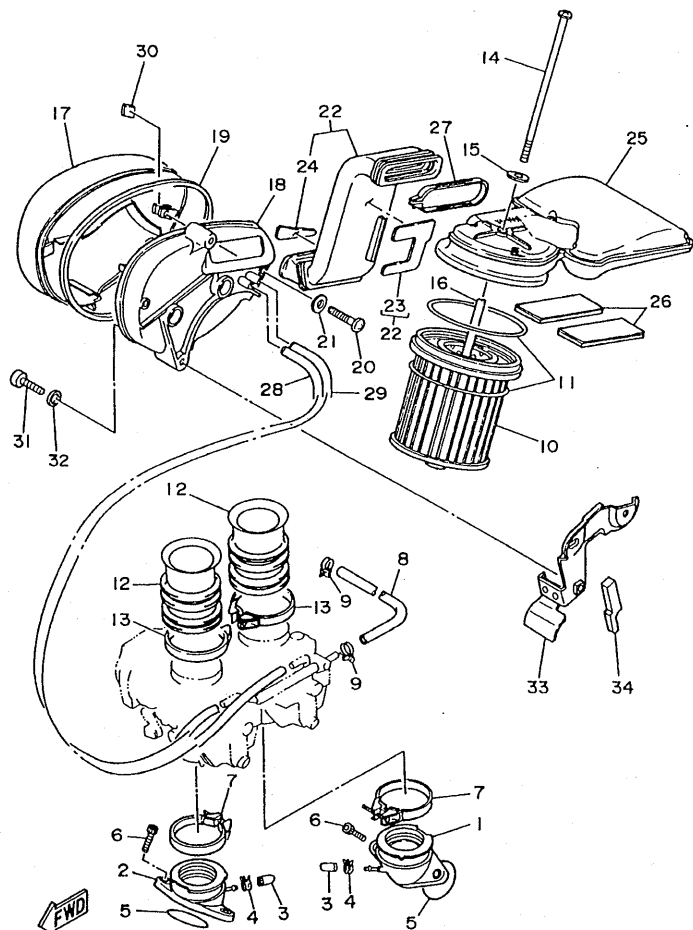

4KUK35I-608I

REF. NO.	CODIGO NO.	DESCRIPCION	4/HB			OBSERVACION
1	2GV-13586-01	TOBERA DE CARBURADOR 1	1			
2	2GV-13596-00	TOBERA DE CARBURADOR 2	1			
3	16G-13569-00	TAPON CIEGO	2			
4	90467-10039	PRESILLA	2			
5	93210-36769	ANILLO O	2			
6	91317-06020	PERNO	4			
7	90460-52210	BRIDA, DE UNION	2			
8	90445-111F3	TUBO	1			
9	90460-12256	BRIDA, DE UNION	2			
10	2NT-14451-00	ELEMENTO DEL FILTRO DEL AIRE	1			
11	2GV-14452-00	SELLO	2			
12	22U-14469-00	EMBUDO PARA AIRE	2			
13	90460-58124	BRIDA, DE UNION	2			
14	98517-06160	TORNILLO DE CABEZA CON PLANA	1			
15	90201-06380	ARANDELA PLANA	1			
16	90387-062T3	CASQUILLO CON VALONA	1			
17	3JB-14422-00	TAPA CAJA DE FILTRO 2	1			
18	3JB-14417-00	CUBIERTA 1	1			
19	3JB-14452-00	SELLO	1			
20	98507-06035	TORNILLO DE CABEZA CON PLANA	2			
21	92907-06600	ARANDELA	2			
22	3JB-14437-01	CONDUCTO	1			
23	3JB-14426-00	.AMORTIGUADOR 2	1			
24	3JB-1442G-00	.AMORTIGUADOR 3	1			
25	3JB-14412-00	TAPA CAJA DEL FILTRO 1	1			
26	3JB-14409-00	AMORTIGUADOR	2			
27	3JB-14455-00	BANDA	1			

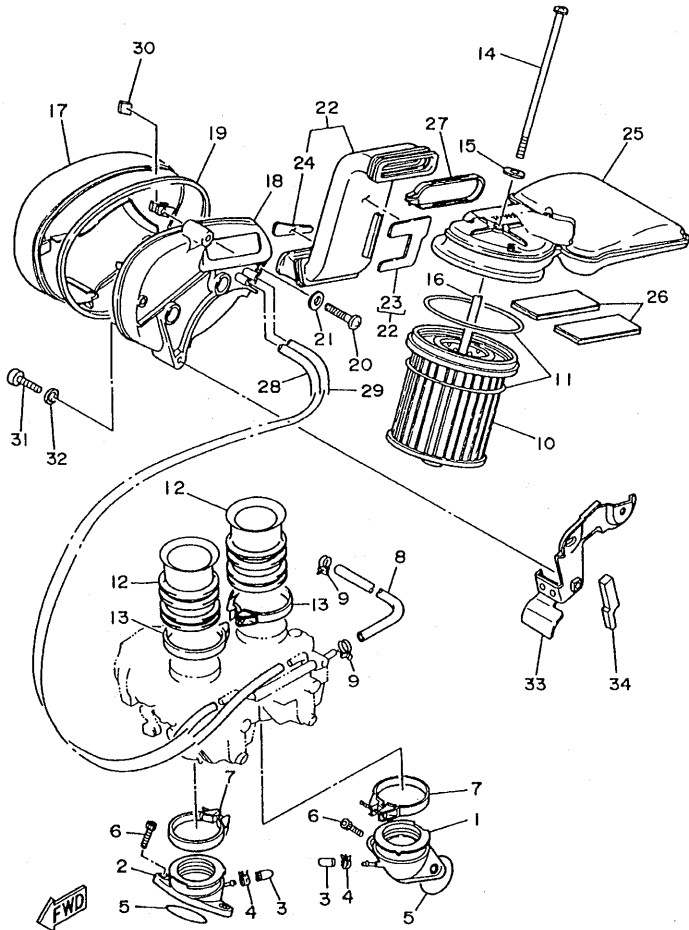

4KUK35I-6081

FIG. 8 ADMISION

REF. NO.	CODIGO NO.	DESCRIPCION	4YHB				OBSERVACION
28	90445-11290	TUBO	1				
29	90445-11152	TUBO	1				
30	90173-06015	TUERCA CUADRADA	2				
31	91317-06030	PERNO	2				
32	92907-06600	ARANDELA	2				
33	3JB-14414-00	SOPORTE 2	1				
34	3JB-14425-00	AMORTIGUADOR 1	1				

FIG. 9 CARBURADOR

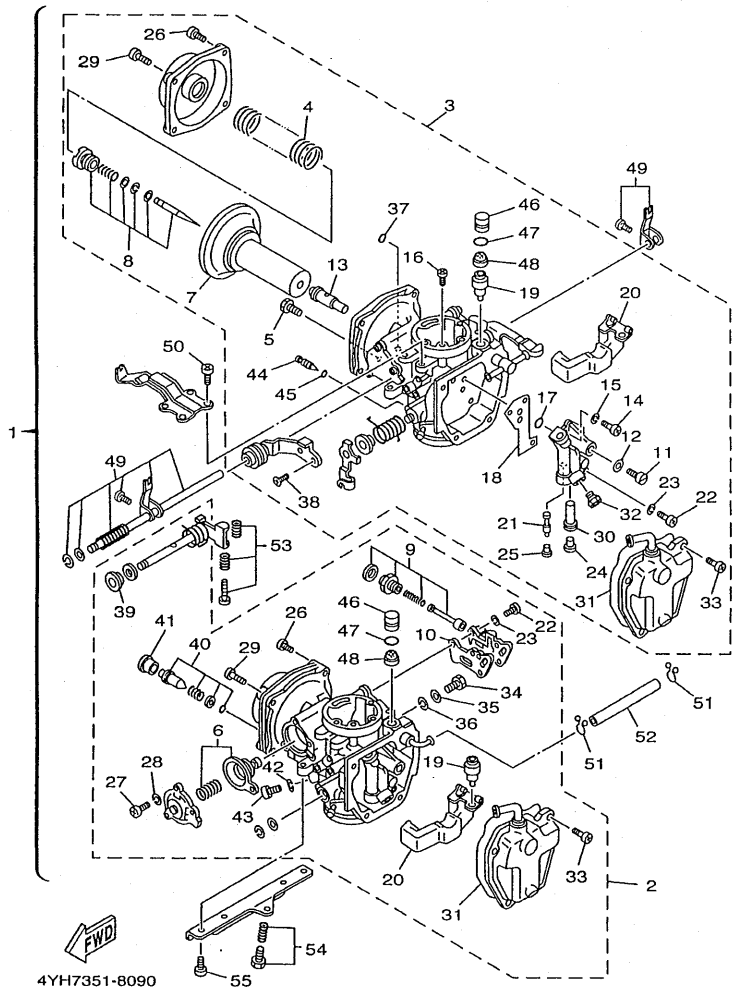

4YH7351-8090

REF. NO.	CODIGO NO.	DESCRIPCION	4YHB			OBSERVACION
1	4KU-14900-12	CARBURADOR COMPLETO	1			
2	4KU-14901-12	..CARBURADOR COMPLETO 1	1			
3	4KU-14902-12	..CARBURADOR COMPLETO 2	1			
4	1FK-14933-00	..RESORTE DE DIAFRAGMA	1			
5	3G2-14231-34	..SURTIDOR DE RALENTI (#170)	1			
6	22U-1490H-00	..DIAFRAGMA	1			
7	41R-14940-00	..DIAFRAGMA COMPLETO	1			
8	3BM-1490J-00	..CJTO. AGUJA	1			UR FRONT
	3BM-1490J-10	..CJTO. AGUJA	1			UR REAR
9	11H-1410A-00	..JUEGO DE ARRANQUE	1			
10	3JB-14536-00	..EMPAQUE	1			
11	22U-14565-00	..TORNILLO	1			
12	137-14153-00	..ARANDELA SURTIDOR PPAL.	1			
13	2JU-14141-90	..BOQUILLA PRINCIPAL	1			
14	98502-04018	..TORNILLO DE CABEZA CON PLAN	1			
15	92902-04100	..ARANDELA	1			
16	3G2-14231-14	..SURTIDOR DE RALENTI (#70)	1			
17	22U-14147-00	..ANILLO O	1			
18	3JB-14199-00	..EMPAQUE	1			
19	1FK-14190-15	..VALVULA DE OBTURACION	1			
20	1FK-14985-00	..BOÍA	1			
21	4G0-14142-35	..SURTIDOR DE RALENTI (# 35)	1			
22	98501-04012	..TORNILLO DE CABEZA CON PLAN	4			
23	92901-04100	..ARANDELA	4			
24	22U-14968-00	..TAPA	1			
25	22V-14968-00	..TAPA	1			
26	97880-05014	..TORNILLO DE CABEZA CON PLAN	3			

FIG. 9 CARBURADOR

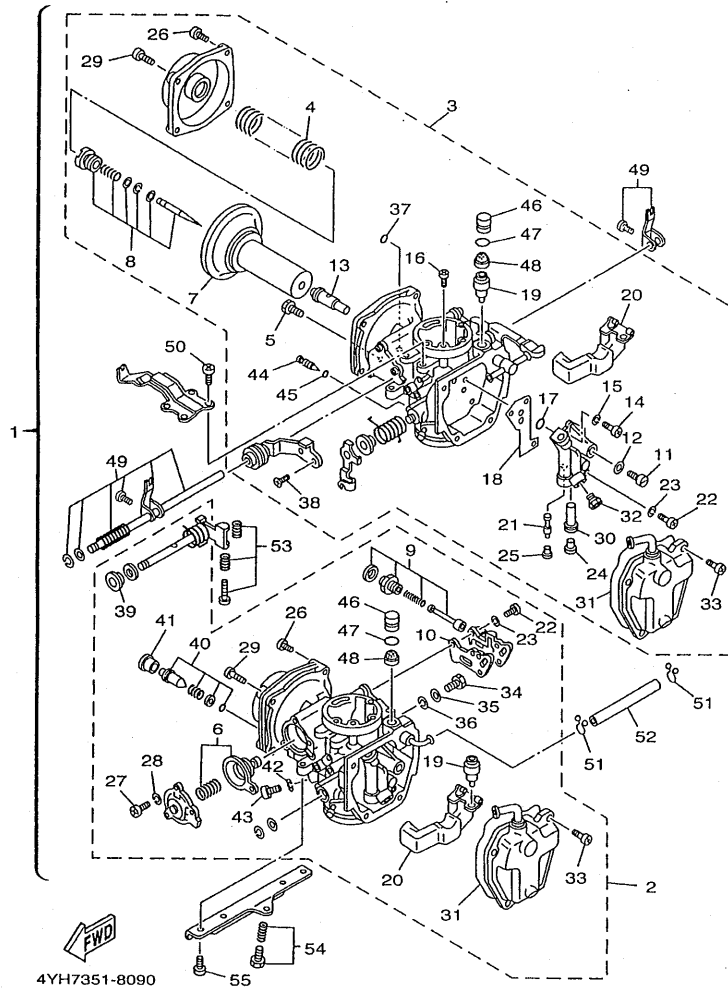

4YH7351-8090

REF. NO.	CODIGO NO.	DESCRIPCION	4YHB			OBSERVACION
27	98501-04010	..TORNILLO DE CABEZA CON PLAN	3			
28	92901-04100	..ARANDELA	3			
29	90157-05050	..TORNILLO CABEZA CONICA PLAN	1			
30	4FT-1414G-00	..AEUJA DE CARB.	1			
31	22V-14147-00	..ANILLO O	1			
32	3G2-1423A-72	..INYECTOR, PRINCIPAL (#107.5)	1			
33	98501-05012	..TORNILLO DE CABEZA CON PLAN	4			
34	341-14991-00	..TORNILLO	1			
35	26H-14952-00	..ARANDELA	1			
36	22U-14952-00	..ARANDELA	1			
37	93210-03119	..ANILLO O	1			
38	92701-06010	..TORNILLO DE CABEZA PLANA	2			
39	341-14954-00	..ARANDELA	1			
40	12R-14105-00	..TORNILLO DE PILOTO	1			
41	22F-14991-00	..TORNILLO	1			
42	127-14198-00	..EMPAQUE	2			
43	92502-08014	..TORNILLO CABEZA CONICA PLAN	2			
44	2L1-14191-00	..TORNILLO, DE DRENAJE	1			
45	214-14147-00	..ANILLO O	1			
46	41R-14118-01	..TAPA	1			
47	1FK-14147-00	..ANILLO O	1			
48	1HX-14994-00	..FILTRO	1			
49	3BM-1490L-00	JUEGO DE PALANCA DE ARRANQUE	1			
50	98501-05010	..TORNILLO DE CABEZA CON PLANA	4			
51	90467-10041	..PRESILLA	2			
52	31H-14987-00	..TUBO	1			
53	3EN-1490K-00	JUEGO DE TORNILLOS DE TOPE	1			

FIG. 9 CARBURADOR

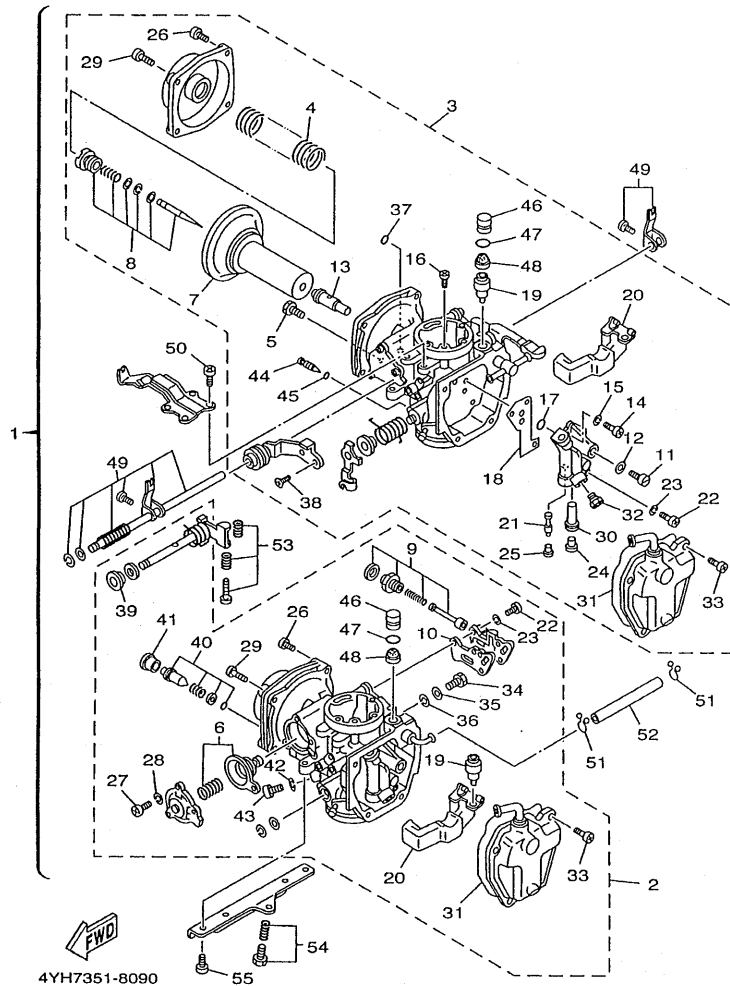

4YH7351-8090

REF. NO.	CODIGO NO.	DESCRIPCION	4YHB				OBSERVACION
54	22U-14103-00	.CJTO. TORNILLO DEL RALENTI	1				
55	98507-06012	.TORNILLO DE CABEZA CON PLANA	4				

FIG. 10 DESCARGA

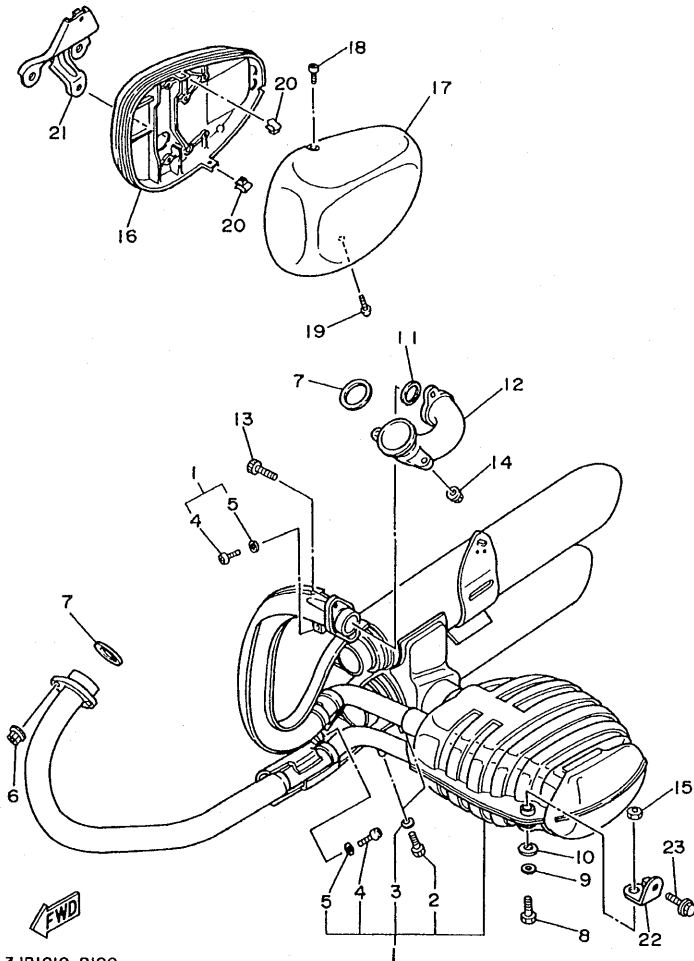

3JB1010-9100

REF. NO.	CODIGO NO.	DESCRIPCION	4Y/HB				OBSERVACION
1	4KU-14703-00	SILENCIADOR COMPL. 1	1				
2	90101-06576	.TORNILLO	2				
3	92990-06600	.ARANDELA	2				
4	98504-06020	.TORNILLO DE CABEZA CON PLANA	2				
5	92903-06600	.ARANDELA	2				
6	90179-08410	TUERCA	2				
7	4BE-14613-00	JUNTA, TUBO DE ESCAPE	2				
8	97027-08030	PERNO	1				
9	92907-08100	ARANDELA	1				
10	92907-08200	ARANDELA	1				
11	4BR-14613-00	JUNTA, TUBO DE ESCAPE	1				
12	2GV-14625-00	EMPAQUE DE ESCAPE 2	1				
13	91317-06025	PERNO	2				
14	90185-08097	TUERCA AUTOBLOCANTE	2				
15	95317-08700	TUERCA	1				
16	2GV-14663-00	PLACA	1				
17	2GV-14603-00	ZAPATA DE CORREDERA	1				
18	97704-40012	TORNILLO ROSCA HEMBRA	1				
19	90163-04003	TORNILLO ROSCA HEMBRA	1				
20	90183-04027	TUERCA DE RESORTE	2				
21	2GV-14484-00	PLACA	1				
22	2GV-2138L-00	SOPORTE 2	1				
23	95807-08016	TUERCA DE REBORDE	1				

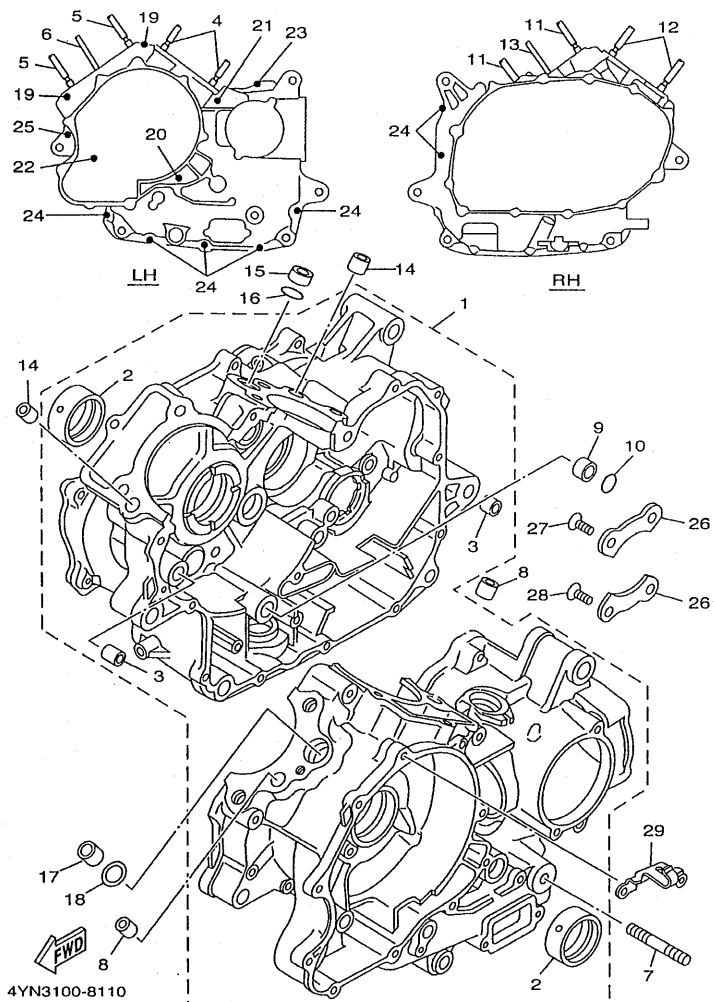
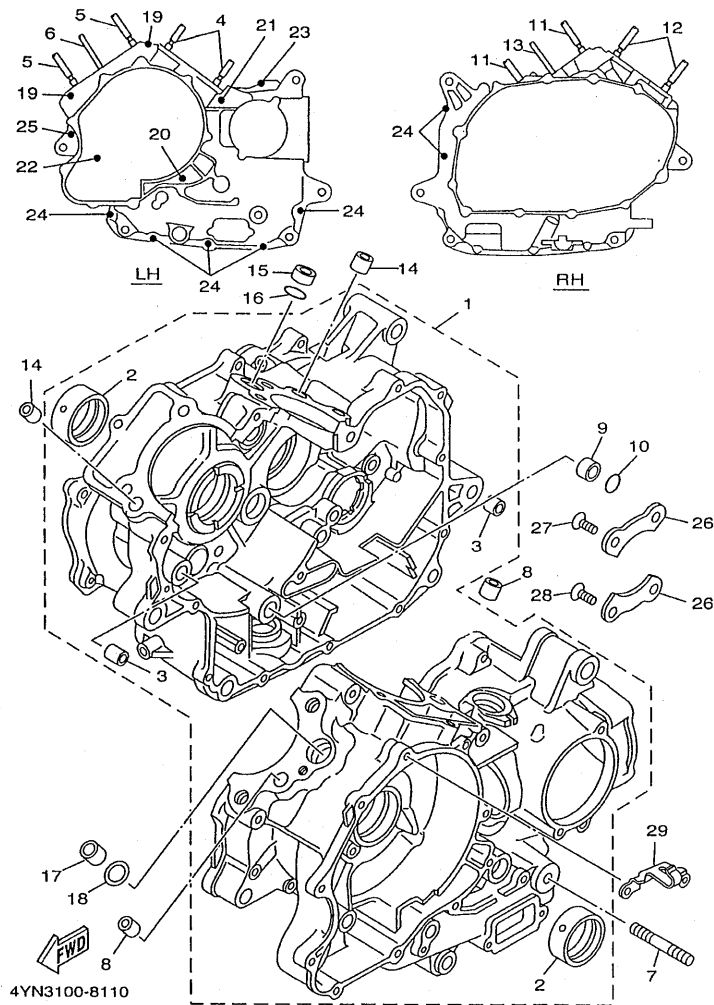

FIG. 11 CARTER

REF. NO.	CODIGO NO.	DESCRIPCION	4Y/HB	OBSERVACION
1	2GV-15100-03	CARTER COMPLETO	1	
2	22U-11416-80	.COJINETE PLANO 1	2	UR AZUL
	22U-11416-90	.COJINETE PLANO 1	2	UR VERDE
3	91815-16017	.PASADOR DE CLAVIJA	2	
4	90116-10406	ESPARRAGO	2	
5	90116-10405	ESPARRAGO	2	
6	90116-08404	ESPARRAGO	1	
7	95617-10680	PERNO DE PUNTAL	1	
8	99530-14016	PASADOR, DE ESPIGA	2	
9	90387-16547	CASQUILLO CON VALONA	1	
10	93210-18322	ANILLO O	1	
11	90116-10406	ESPARRAGO	2	
12	90116-10405	ESPARRAGO	2	
13	90116-08404	ESPARRAGO	1	
14	99530-14016	PASADOR, DE ESPIGA	2	
15	90387-16547	CASQUILLO CON VALONA	1	
16	93210-18322	ANILLO O	1	
17	90387-16547	CASQUILLO CON VALONA	1	
18	93210-18322	ANILLO O	1	
19	91314-08060	PERNO	2	
20	91317-08080	PERNO	1	
21	91314-08100	PERNO	1	
22	91317-06095	PERNO	1	
23	91314-06045	PERNO	1	
24	91317-06045	PERNO	7	
25	91314-06055	PERNO	1	
26	11H-15383-01	PLACA CUBIERTA DE ENGRANAJE	2	

FIG. 11 CARTER



REF. NO.	CODIGO NO.	DESCRIPCION	4Y/HB				OBSERVACION
27	90151-08022	TORNILLO EMBUTIDO	1				
28	90149-08152	TORNILLO DE REGLAJE	3				
29	22U-15441-01	SOSTEN DE CABLE DE EMBRAGUE	1				

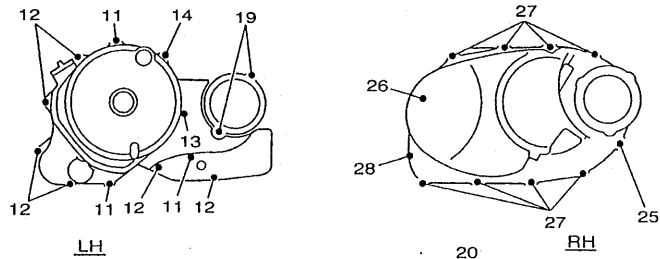

LH

RH

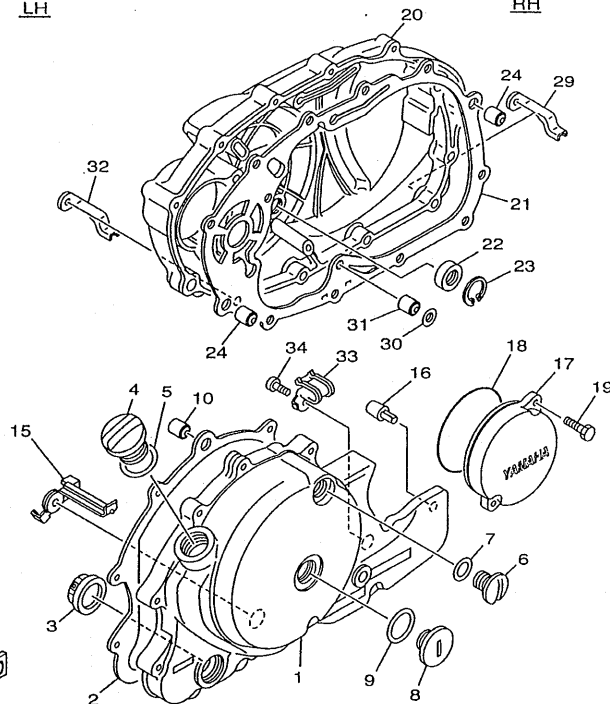

4YN3100-8120

FIG. 12 CUBIERTA DE CARTER 1

REF. NO.	CODIGO NO.	DESCRIPCION	AYHB			OBSERVACION
1	3JB-15411-01	CUBIERTA DE CARTER 1	1			
2	4VR-15451-00	EMPAQ DE CUBIERTA DE CARTER	1			
3	2H7-15361-00	MEDIDOR DE NIVEL	1			
4	3F9-15362-00	TAPON DEL NIVEL DE ACEITE	1			
5	93210-27370	ANILLO O	1			
6	90340-14139	TORNILLO, DE DRENAJE	1			
7	93210-14369	ANILLO O	1			
8	90340-32140	TORNILLO, DE DRENAJE	1			
9	93210-32172	ANILLO O	1			
10	99530-10014	PASADOR, DE ESPIGA	2			
11	91314-06040	PERNO	3			
12	91314-06025	PERNO	6			
13	91314-06055	PERNO	1			
14	91314-06030	PERNO	1			
15	3BT-15484-00	GRAMPA 2	1			
16	2GV-15316-00	AMORT. MONTANTE MOTOR 1	1			
17	3JB-15415-00	CUBIERTA DE GENERADOR	1			
18	93210-74316	ANILLO O	1			
19	91314-06018	PERNO	2			
20	3JB-15421-00	TAPA DE CARTER DERECHA	1			
21	4VR-15461-00	JUNTA TAPA CARTER DERECHO	1			
22	93101-14089	SELLO ACEITE	1			
23	99009-25500	PRESILLA REDONDA	1			
24	99530-10120	PASADOR, DE ESPIGA	2			
25	91314-06040	PERNO	1			
26	91314-06055	PERNO	1			
27	91314-06025	PERNO	8			

FIG. 12 CUBIERTA DE CARTER 1

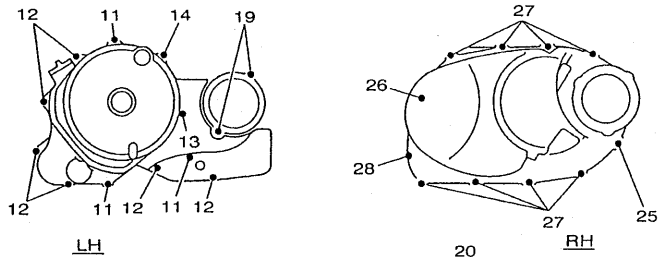

LH

RH

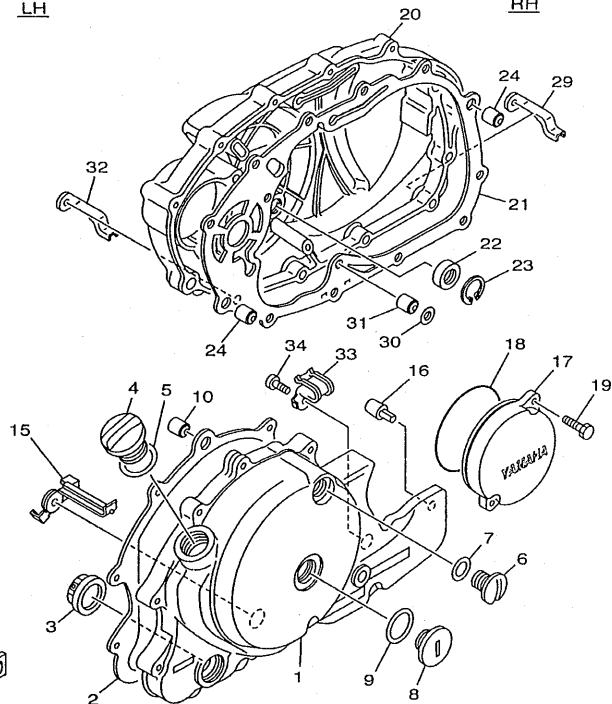

4YN3100-8120

REF. NO.	CODIGO NO.	DESCRIPCION	4YHB				OBSERVACION
28	91380-06025	PERNO	1				
29	90462-10115	BRIDA	2				
30	93210-15566	ANILLO O	1				
31	91815-16017	PASADOR DE CLAVIJA	1				
32	90462-10118	BRIDA	2				
33	90462-06119	BRIDA	1				
34	98507-06010	TORNILLO DE CABEZA CON PLANA	1				

FIG. 13 EMBRAG. DEL ARRANQUE

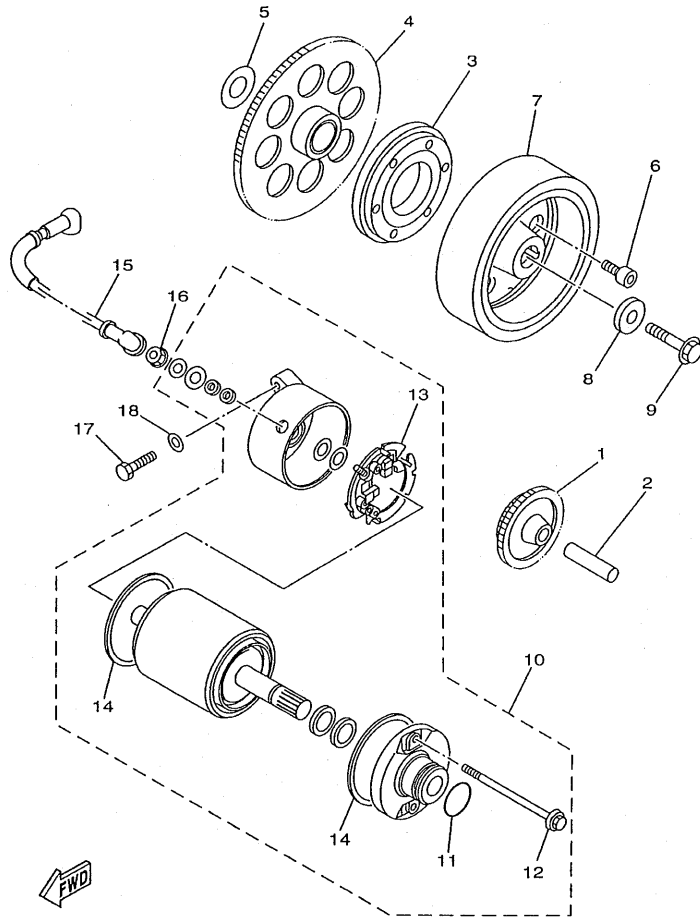

FWD
4YHB300-0140

REF. NO.	CODIGO NO.	DESCRIPCION	4YHB				OBSERVACION
1	22U-15512-00	ENGRENAJE NEUTRO	1				
2	5H0-15521-00	EJE 1	1				
3	4TR-15590-00	ENSAMBLE GUIA CADENA ARRANQUE	1				
4	4TR-15517-00	ENGRENAJE POSICION 2DA	1				
5	90201-25290	ARANDELA PLANA	1				
6	90110-08212	TORNILLO ALLEN	6				
7	4TR-81450-00	ROTOR COMPLETO	1				
8	90201-107E9	ARANDELA PLANA	1				
9	90105-10152	TORNILLO CON ARANDELA	1				
10	3JB-81890-00	MOTOR DE ARRANQUE COMPLETO	1				
11	1FK-81847-00	.ANILLO GOMA	1				
12	3HE-81826-00	.PERNO	2				
13	3KS-81840-00	.SOSTEN DE ESCOBILLA COMPLETO	1				
14	11H-81844-00	.EMPAQUE	2				
15	1HX-81815-00	CABLE, MOTOR DE ARRANQUE	1				
16	4XV-8182A-00	TUERCA	1				
17	97070-06025	PERNO	2				
18	92990-06600	ARANDELA	2				

FIG. 14 EMBRAGUE

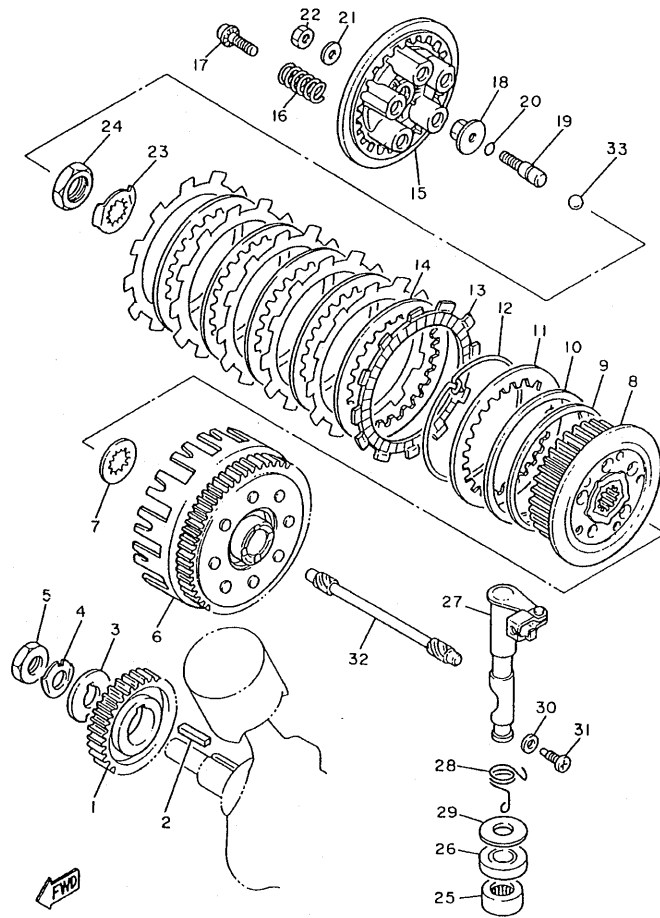

22U110-3160

REF. NO.	CODIGO NO.	DESCRIPCION	4Y/HB				OBSERVACION
1	4KU-16111-00	ENGRANAJE TRACC.PRIMARIA	1				
2	90280-07036	CUNA WOODRUFF	1				
3	90214-16026	ARANDELA DE POSICION	1				
4	90215-16157	ARANDELA DE CIERRE	1				
5	90170-16256	TUERCA	1				
6	22U-16150-01	CAMPANA DE EMBRAGUE	1				
7	22U-16154-00	ARANDELA, DE EMPUJE 1	1				
8	22U-16371-02	CUBO, DE EMBRAGUE	1				
9	4X7-16384-00	PLACA DE ASIENTO	1				
10	4X7-16383-01	RESORTE DE COPA DE EMBRAGUE	1				
11	4X7-16324-00	PLACA DE EMBRAGUE	1				
12	4X7-16385-00	RESORTE DE COPA DE EMBRAGUE	1				
13	22U-16321-00	PLACA DE FRICCION	6				
14	4X7-16325-00	DISCO, DE EMBRAGUE	5				
15	22U-16351-00	PLATO DE PRESION	1				
16	90501-23738	RESORTE DE COMPRESION	5				
17	90159-06016	TORNILLO CON VALONA	5				
18	1W1-16358-01	PLACA DE EMPUJE	1				
19	4PT-16356-01	VARILLA DE EMPUJE 1	1				
20	93210-09525	ANILLO O	1				
21	92907-06200	ARANDELA	1				
22	95307-06600	TUERCA	1				
23	90215-22210	ARANDELA DE CIERRE	1				
24	90170-20310	TUERCA	1				
25	93315-21813	COJINETE	1				
26	93102-18278	SELLO ACEITE	1				
27	22U-16380-00	LEVA DE EMPUJE COMPLETA	1				

FIG. 14 EMBRAGUE

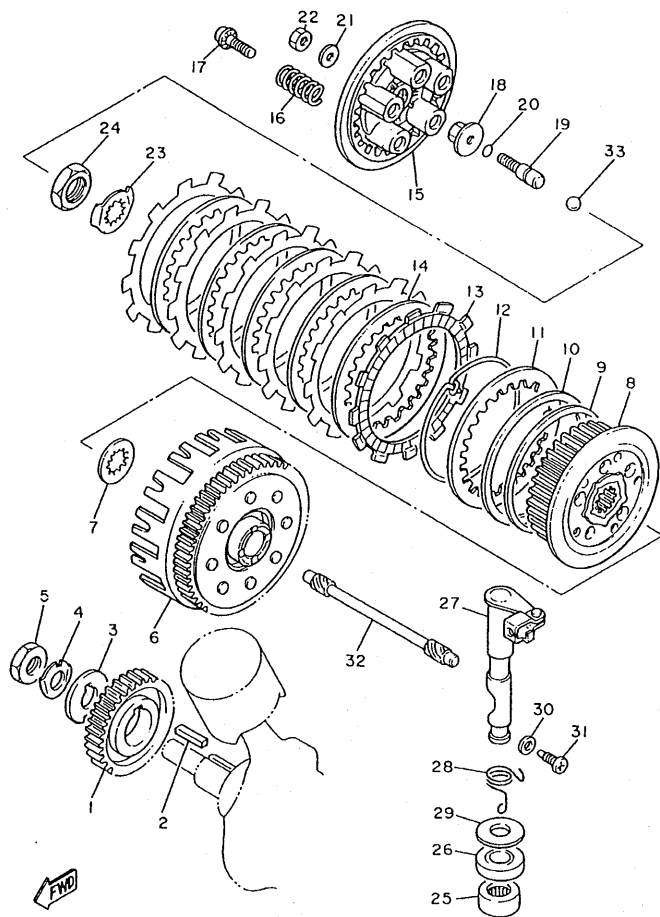

22U110-3160

REF. NO.	CODIGO NO.	DESCRIPCION	AYHB				OBSERVACION
28	90508-16577	RESORTE DE TORSION	1				
29	90201-18262	ARANDELA PLANA	1				
30	90430-08119	JUNTA	1				
31	90149-08067	TORNILLO DE REGLAJE	1				
32	22U-16357-00	VARILLA DE EMPUJE 2	1				
33	93515-32029	BOLA	1				

FIG. 15 TRANSMISION

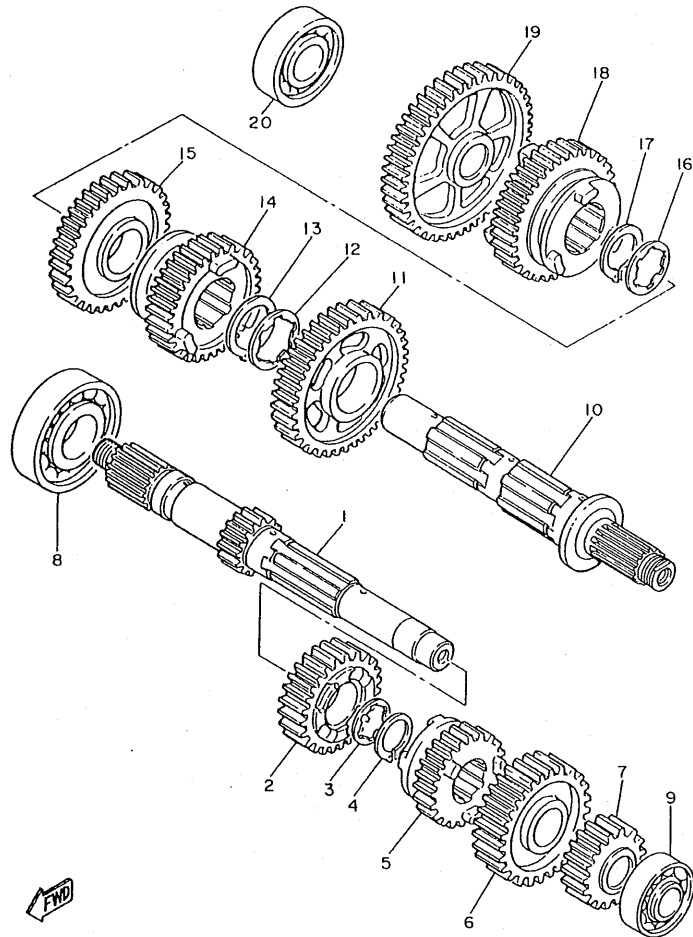

REF. NO.	CODIGO NO.	DESCRIPCION	4YHB				OBSERVACION
1	4VR-17411-00	EJE PRIMARIO	1				
2	22U-17141-00	ENGRANAJE PINON DE 4TA	1				
3	90209-22191	ARANDELA DE SEPARACION	1				
4	93440-25084	BOLA	1				
5	4KU-17131-00	ENGRANAJE PINON DE 3RA	1				
6	11H-17151-01	ENGRANAJE PINON DE 5TA	1				
7	4KU-17121-00	ENGRANAJE DE PINON DE 2DA	1				
8	93306-30525	COJINETE (B6305)	1				
9	93306-00401	COJINETE (B6004)	1				
10	22U-17402-00	EJE DE TRACCION COMPLETO	1				
11	4KU-17221-00	ENGRANAJE RUEDA DE 2DA	1				
12	90209-27192	ARANDELA DE SEPARACION	1				
13	93440-30077	BOLA	1				
14	11H-17251-00	ENGRANAJE RUEDA DE 5TA	1				
15	4KU-17231-00	ENGRANAJE RUEDA DE 3RA	1				
16	90209-22191	ARANDELA DE SEPARACION	1				
17	93440-25084	BOLA	1				
18	22U-17241-00	ENGRANAJE DE RUEDA 4TA	1				
19	22U-17211-00	ENGRANAJE RUEDA DE 1 RA	1				
20	93306-00428	COJINETE	1				



2GV110-7150

FIG. 16 ENGR. MEDIO DE TRAC.

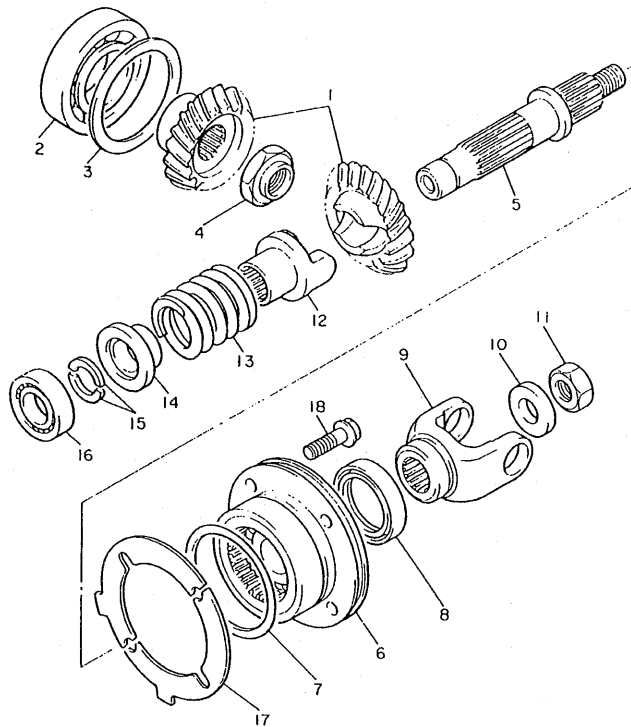

REF. NO.	CODIGO NO.	DESCRIPCION	4YHB			OBSERVACION
1	22U-Y1754-00	ENGRANAJE MEDIO COMPLETE	1			
2	93306-20711	COJINETE	1			
3	4H7-17537-00-20	CUNA DE EMPUJE	1			UR
	4H7-17537-00-30	CUNA DE EMPUJE	1			UR
	4H7-17537-00-40	CUNA DE EMPUJE	1			UR
4	90179-18396	TUERCA	1			
5	22U-17553-01	EJE MEDIO IMPULSOR	1			
6	4H7-W1752-10	CAJA COMPLETE	1			
7	93210-71360	ANILLO O	1			
8	93101-35097	SELLO ACEITE	1			
9	22U-17556-00	YUGO DE ARTICULACION	1			
10	90201-14633	ARANDELA PLANA	1			
11	90185-14070	TUERCA AUTOBLOCANTE	1			
12	22U-17527-01	LEVA DE IMPULSION	1			
13	90501-60716	RESORTE DE COMPRESION	1			
14	22U-17524-00	SOSTEN	1			
15	3H5-17529-00	ARANDELA DE EMPUJE	2			
16	93306-00401	COJINETE (B6004)	1			
17	3JB-17531-00	CUNA, DE PINON (0.10T)	2			UR
	3JB-17531-10	CUNA, DE PINON (0.15T)	2			UR
	3JB-17531-20	CUNA, DE PINON (0.20T)	2			UR
18	95827-08030	TUERCA DE REBORDE	4			



22U110-3180

FIG. 17 LEVA DE CAMBIO. HORQ

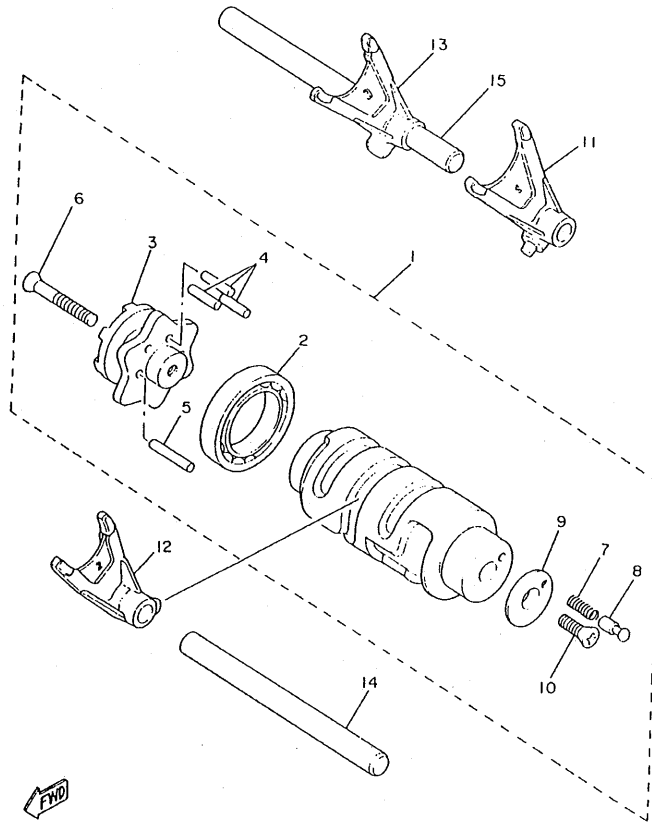

22U110-3190

REF. NO.	CODIGO NO.	DESCRIPCION	4YHB				OBSERVACION
1	4TR-18540-02	LEVADEL CAMBIO COMPLETA	1				
2	93306-90602	.COJINETE	1				
3	4H7-18185-00	.SEGMENTO DE RETENCION	1				
4	93604-16092	.PASADOR DE CLAVIJA	3				
5	93604-20156	.PASADOR DE CLAVIJA	1				
6	98707-05035	.TORNILLO DE CABEZA PLANA	1				
7	90501-06022	.RESORTE DE COMPRESION	1				
8	4UN-18542-00	.PUNTO MVERTO	1				
9	4UN-18566-00	.PLACA LATERAL 2	1				
10	90149-05321	.TORNILLO DE REGLAJE	1				
11	4TR-18511-00	HORQUILLA DEL CAMBIO 1	1				
12	4TR-18512-00	HORQUILLA DEL CAMBIO 2	1				
13	4TR-18513-00	HORQUILLA DE CAMBIO 3	1				
14	3YF-18531-00	BARRA GUIA HORQ. CAMBIO 1	1				
15	4TR-18535-00	BARRA GUIA HORQ. CAMBIO 2	1				

FIG. 18 EJE DE CAMBIO. PEDAL

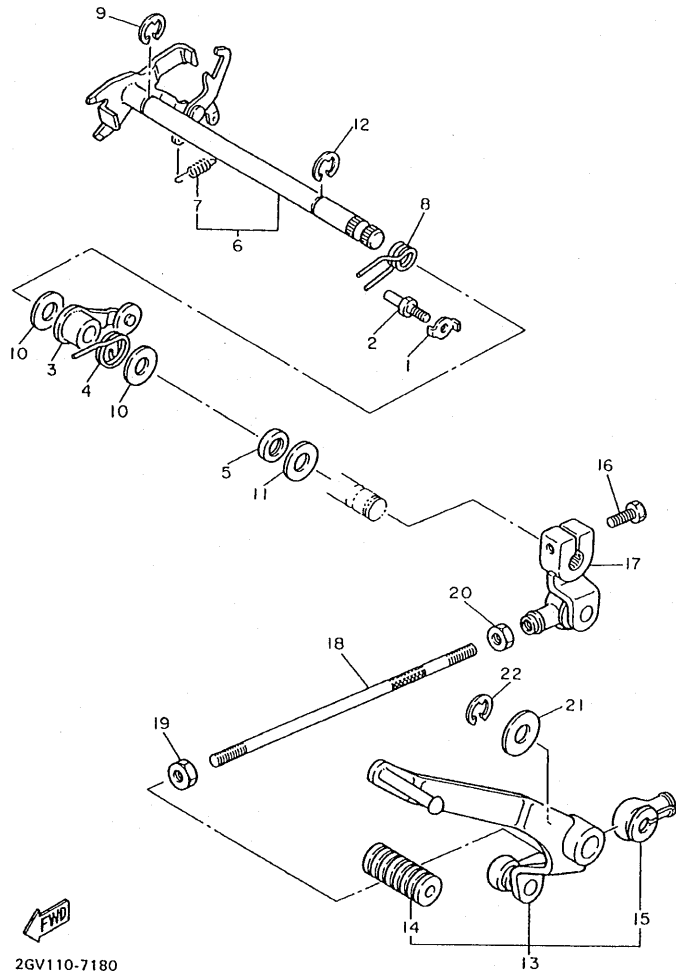

2GV110-7180

REF. NO.	CODIGO NO.	DESCRIPCION	4YHB				OBSERVACION
1	90215-18178	ARANDELA DE CIERRE	1				
2	4G0-18127-00	PASADOR DE PALANCA	1				
3	4TR-18140-00	PALANCA DE TOPE COMPLETA	1				
4	90508-290B5	RESORTE DE TORSION	1				
5	93102-12106	SELLO ACEITE (SD 12-22-5 HS)	1				
6	22U-18120-02	PALANCA DE SELECTOR COMPLETO	1				
7	90506-08227	.RESORTE DE TENSION	1				
8	90508-32536	RESORTE DE TORSION	1				
9	99001-10600	PRESILLA REDONDA	1				
10	90201-12588	ARANDELA PLANA	2				
11	90201-12575	ARANDELA PLANA	1				
12	99001-10600	PRESILLA REDONDA	1				
13	2GV-18110-00	PEDAL DE CAMBIO COMPLETO	1				
14	132-18113-01	.FUNDA DEL PEDAL DEL CAMBIO	1				
15	2H9-18154-00	.CUBIERTA GUARDAPOLVO	1				
16	97024-06020	PERNO	1				
17	2GV-18112-00	BRAZO DEL CANBIO	1				
18	2GV-18115-00	VARILLA DEL CANBIO	1				
19	90170-06228	TUERCA	1				
20	95304-06700	TUERCA	1				
21	90201-12688	ARANDELA PLANA	1				
22	99009-12400	PRESILLA REDONDA	1				

FIG. 19 CUADRO

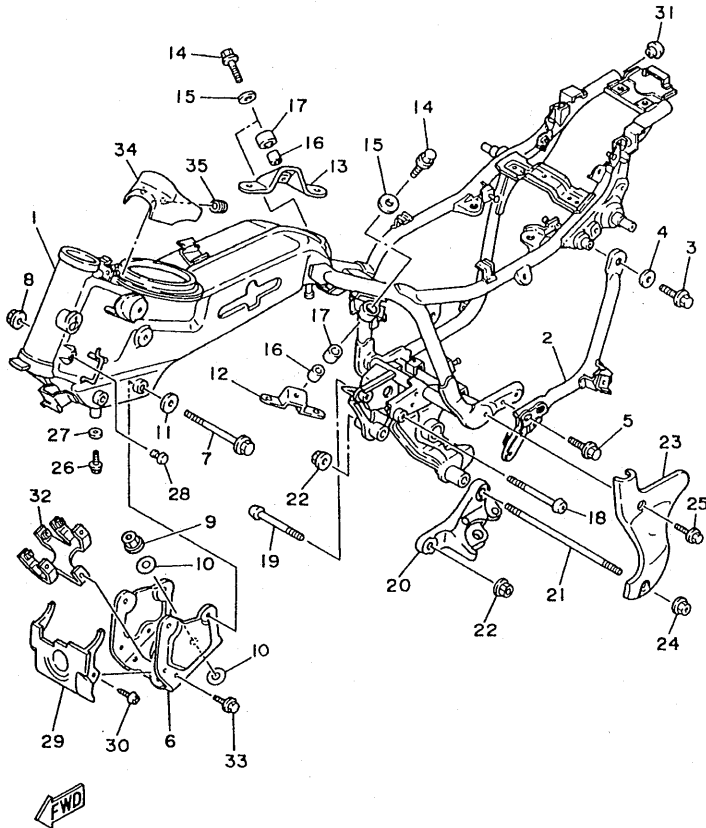

3JCG100-5190

REF. NO.	CODIGO NO.	DESCRIPCION	4YHB				OBSERVACION
1	4FT-21110-10-33	ARMAZON COMPLETO	1				YB
2	3JB-21105-00-33	SUBSOPORTE DEL RESPALDO COMP.	1				YB
3	90105-08066	TORNILLO CON ARANDELA	1				
4	90201-08326	ARANDELA PLANA	1				
5	90109-08718	PERNO	2				
6	2GV-21317-00	SOPORTE DE MOTOR 3	1				
7	90105-10183	TORNILLO CON ARANDELA	2				
8	90179-10247	TUERCA	2				
9	90179-10279	TUERCA	4				
10	90201-10131	ARANDELA PLANA	4				
11	90201-10140	ARANDELA PLANA	2				
12	22U-21315-00	SOPORTE DE MOTOR 2	1				
13	22U-21316-00	SOPORTE DE MOTOR 3	1				
14	90105-10186	TORNILLO CON ARANDELA	2				
15	90201-104A7	ARANDELA PLANA	2				
16	90387-100E2	CASQUILLO CON VALONA	2				
17	4X7-21485-00	AMORTIGUADOR DE GOMA 1	2				
18	90149-10238	TORNILLO DE REGLAJE	1				
19	90149-10239	TORNILLO DE REGLAJE	1				
20	4KU-21458-00	SOPORTE DE PUNTAL LATERAL	1				
21	90116-12495	ESPARRAGO	1				
22	90179-12248	TUERCA	2				
23	2GV-2171E-00	CUBIERTA LATERAL 5	1				
24	95307-12800	TUERCA	1				
25	95027-06016	PERNO, DE BRIDA	1				
26	90105-06069	TORNILLO CON ARANDELA	1				
27	90202-05193	ARANDELA DE PLANA	1				

FIG. 19 CUADRO

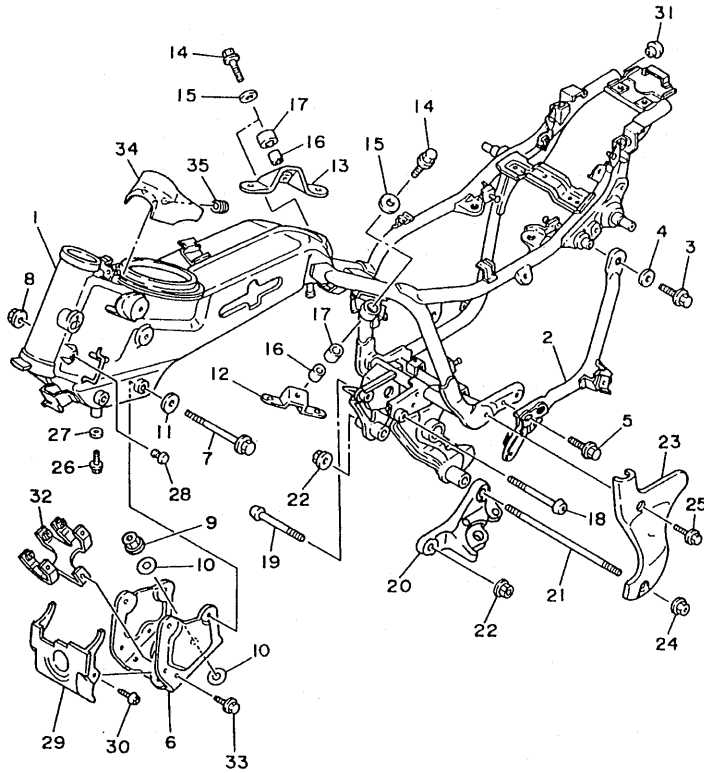

3JCG100-5190

REF. NO.	CODIGO NO.	DESCRIPCION	4Y/HB			OBSERVACION
28	90338-07043	TAPON	4			
29	2GV-2139R-00	CUBIERTA 2	1			
30	97707-60514	TORNILLO ROSCA HEMBRA	2			
31	1AA-2143A-00	TAPA	2			
32	2GV-21359-00	SOPORTE DE BOBINA	1			
33	95807-06012	TUERCA DE REBORDE	2			
34	3JB-2139R-00	CUBIERTA 2	1			
35	90480-10334	TAPON	2			

FIG. 20 GUARDABARRO

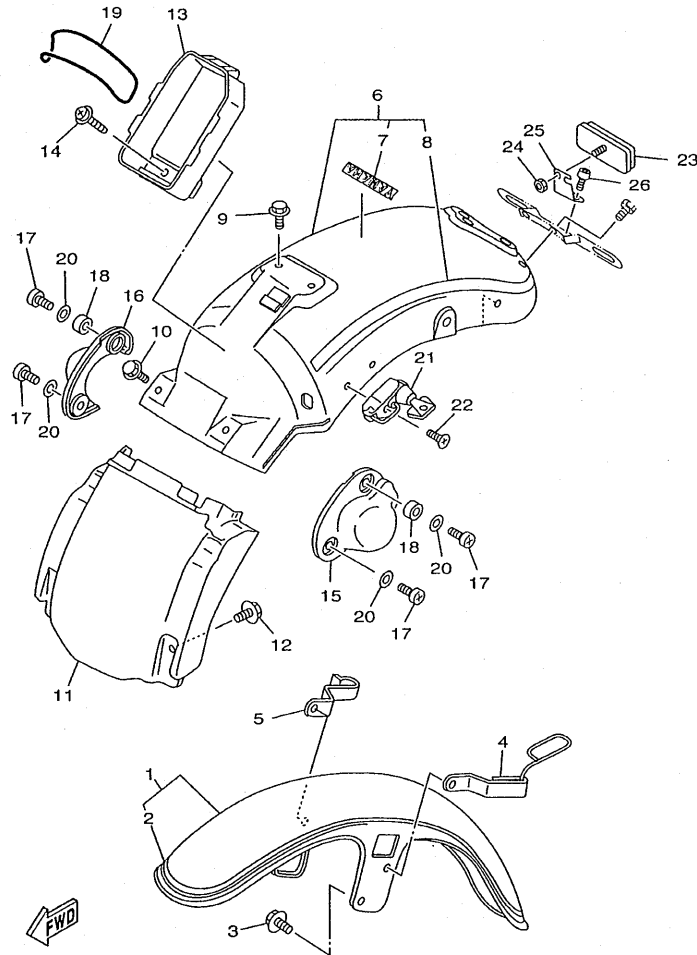

4YH9332-9200

REF. NO.	CODIGO NO.	DESCRIPCION	4YH		OBSERVACION
1	2GV-Y2150-E1-JW	GUARDABARRO DELANTERO COMPLETO	1		UR URB
	2GV-Y2150-K1-PD	GUARDABARRO DELANTERO COMPLETO	1		UR DCM8
	2GV-Y2150-H1-PC	GUARDABARRO DELANTERO COMPLETO	1		UR DYRM2
2	4KU-21570-80	.CALCOMANIAS GUARDABARRO DEL.	1		UR PARA URB
	4KU-21570-C0	.CALCOMANIAS GUARDABARRO DEL.	1		UR PARA DCM8
	4KU-21570-B0	.CALCOMANIAS GUARDABARRO DEL.	1		UR PARA DRYN2
3	95027-08012	PERNO, DE BRIDA	4		
4	2NT-21597-01	SOPORTE DE CABLE 1	1		
5	3JB-21598-00	SOPORTE DE CABLE 2	1		
6	4YH-Y2161-1C-JW	GUARDABARRO TRASERO COMPLETO	1		UR URB
	4YH-Y2161-1E-P2	GUARDABARRO TRASERO COMPLETO	1		UR DCM8
	4YH-Y2161-1F-P1	GUARDABARRO TRASERO COMPLETO	1		UR DYRM2
7	99246-00080	.EMBLEMA, YAMAHA	1		UR PARA URB,DYRM2
	99247-00080	.EMBLEMA, YAMAHA	1		UR PARA DCM8
8	4KU-2165A-80	.JUEGO DE EMBLEMA	1		UR PARA URB
	4KU-2165A-C0	.JUEGO DE EMBLEMA	1		UR PARA DCM8
	4KU-2165A-B0	.JUEGO DE EMBLEMA	1		UR PARA DYRM2
9	95807-08012	TUERCA DE REBORDE	2		
10	95807-06010	TUERCA DE REBORDE	2		
11	2GV-21629-00-JW	GUARDABARRO INFERIOR	1		UR URB
	2GV-21629-00-P7	GUARDABARRO INFERIOR	1		UR DCM8
	2GV-21629-00-P6	GUARDABARRO INFERIOR	1		UR DYRM2
12	90119-06123	TORNILLO CON ARANDELA	2		
13	2GV-2160E-00	CAJA	1		
14	90159-06059	TORNILLO CON VALONA	1		
15	2GV-2163A-00	CUBIERTA TRAS GUARDABARRO 1	1		
16	2GV-2163E-00	CUBIERTA TRAS GUARDABARRO 2	1		

FIG. 20 GUARDABARRO

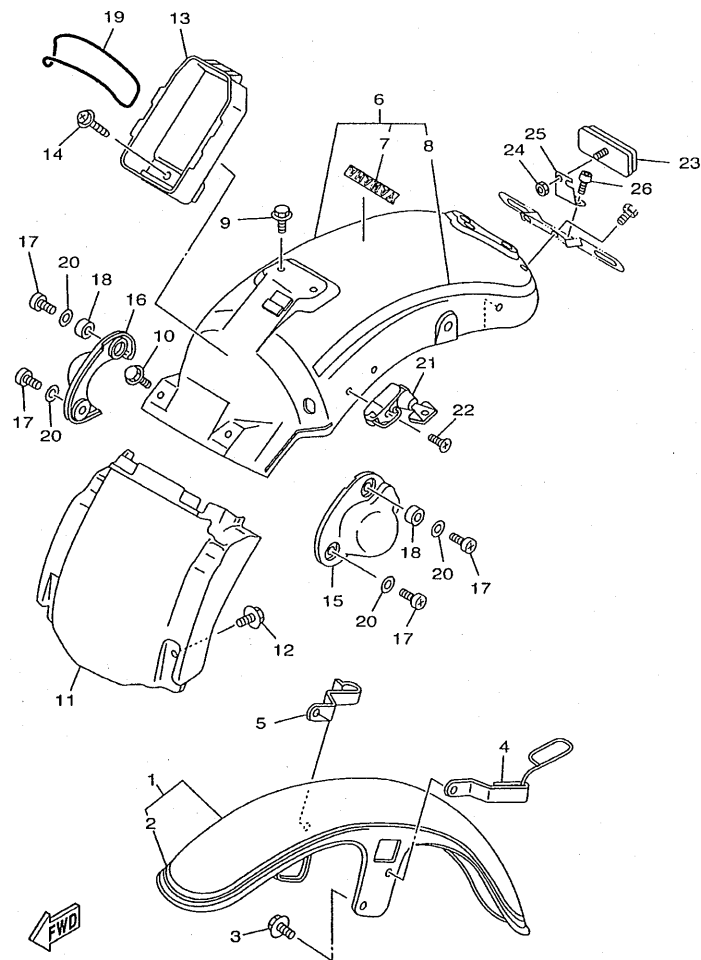

4YH9332-9200

REF. NO.	CODIGO NO.	DESCRIPCION	4YHB				OBSERVACION
17	98904-08014	TORNILLO DE LIGAR	4				
18	90560-08326	SEPARADOR	2				
19	93210-71360	ANILLO O	1				
20	92903-08200	ARANDELA	4				
21	4R8-21308-00	PORTACASCO COMPLETO	1				
22	90149-06154	TORNILLO DE REGLAJE	1				
23	3Y6-85130-02	REFLECTOR TRASERO COMPLETO	1				
24	95307-05600	TUERCA	1				
25	4YH-21641-00	SOPORTE DE REFLECTOR	1				
26	92017-06010	PERNO	1				

FIG. 21 CUBIERTA LATERAL

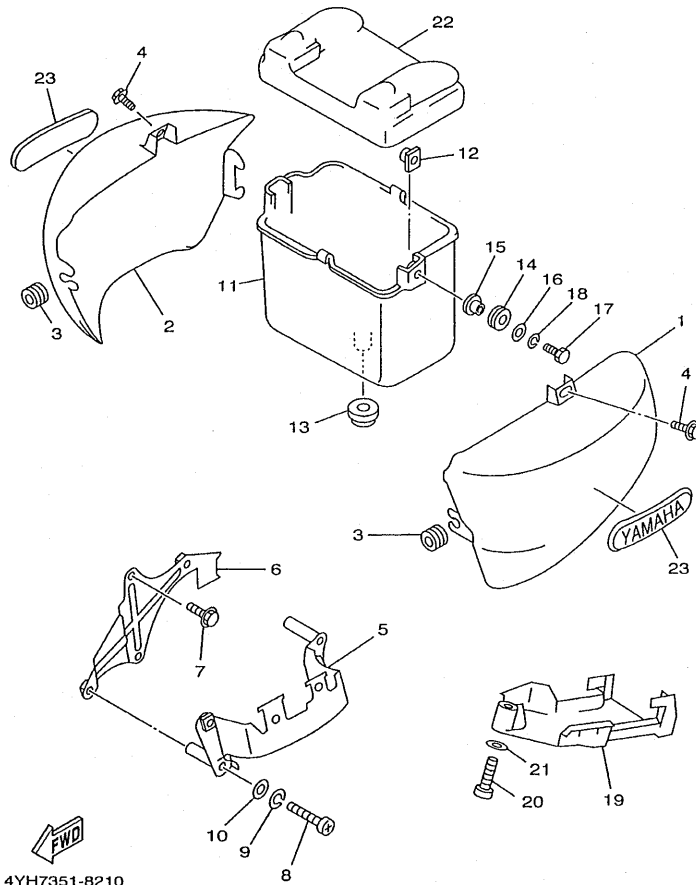

4YH7351-8210

REF. NO.	CODIGO NO.	DESCRIPCION	4YHB	OBSERVACION
1	2GV-21711-00-JW	TAPA LATERAL 1	1	UR URB
	2GV-21711-00-P7	TAPA LATERAL 1	1	UR DCM8
	2GV-21711-00-P6	TAPA LATERAL 1	1	UR DYRM2
2	2GV-21721-00-JW	TAPA LATERAL 2	1	UR URB
	2GV-21721-00-P7	TAPA LATERAL 2	1	UR DCM8
	2GV-21721-00-P6	TAPA LATERAL 2	1	UR DYRM2
3	90480-12320	TAPON	2	
4	90119-06123	TORNILLO CON ARANDELA	2	
5	3JB-2172F-00	PANEL 2	1	
6	3JB-2172E-00	SOPORTE,CUBIERTA LATERAL 1	1	
7	95807-06020	TUERCA DE REBORDE	2	
8	98507-06050	TORNILLO DE CABEZA CON PLANA	2	
9	92907-06100	ARANDELA	2	
10	92907-06600	ARANDELA	2	
11	2GV-21171-00	CAJA	1	
12	31A-14477-00	PLACA	2	
13	90480-22362	TAPON	1	
14	90480-14229	TAPON	2	
15	90387-07391	CASQUILLO CON VALONA	2	
16	90201-06380	ARANDELA PLANA	2	
17	97007-06025	PERÑO	2	
18	92907-06100	ARANDELA	2	
19	3JB-2176E-00	PLACA	1	
20	98507-06035	TORNILLO DE CABEZA CON PLANA	1	
21	92907-06600	ARANDELA	1	
22	3JB-28185-00	TAPA	1	
23	4KU-21781-00	EMBLEMA 1	2	

FIG. 22 BRAZO TRASERO. SUSPENSION

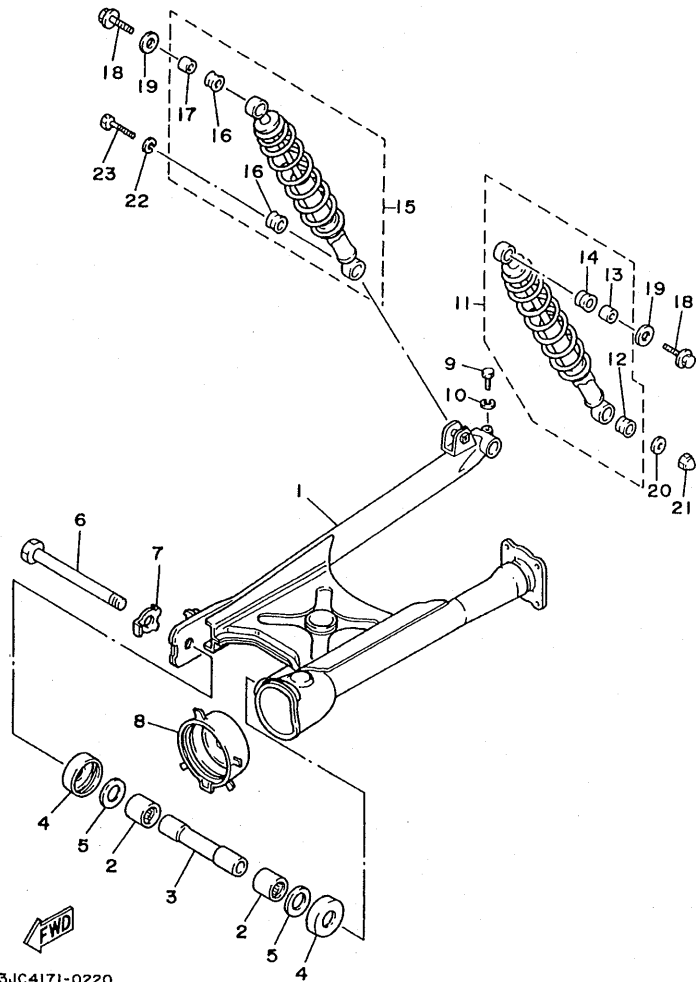

3JC4171-0220

REF. NO.	CODIGO NO.	DESCRIPCION	4YHB			OBSERVACION
1	2GV-22110-00-35	BRAZO TRASERO COMPLETO	1			SL
2	93320-32403	COJINETE	2			
3	4X7-22124-00	BUJE 2	1			
4	4X7-22129-00	TAPA DE EMPUJE 2	2			
5	90201-244A8	ARANDELA PLANA (1.95T)	2			
6	4X7-22141-00	EJE DEL BARCULANTE	1			
7	90215-16181	ARANDELA DE CIERRE	1			
8	22U-22189-00	FUNDA DE GOMA	1			
9	97004-08035	PERNO	1			
10	92904-08100	ARANDELA	1			
11	2YL-22210-01	AMORTIGUADOR TRASERO COMPLETO	1			
12	2GV-22216-00	.BUJE DEL AMORTIGUADOR TRASERO	1			
13	2GV-22253-00	.COLLAR DISTANCIADOR	1			
14	2GV-22226-00	.BUJE DE AMORTIGUADOR INFERIO	1			
15	2YL-22220-01	AMORTIGUADOR TRASERO COMPLETO	1			
16	2GV-22226-00	.BUJE DE AMORTIGUADOR INFERIO	2			
17	5M0-22253-00	.COLLAR DISTANCIADOR	1			
18	95807-08012	TUERCA DE REBORDE	2			
19	90201-08753	ARANDELA PLANA	2			
20	90201-105R9	ARANDELA PLANA	1			
21	90176-10073	TUERCA CORONA	1			
22	92903-10100	ARANDELA	1			
23	90106-10052	PERNO	1			

FIG. 23 EJE DE TRACCION

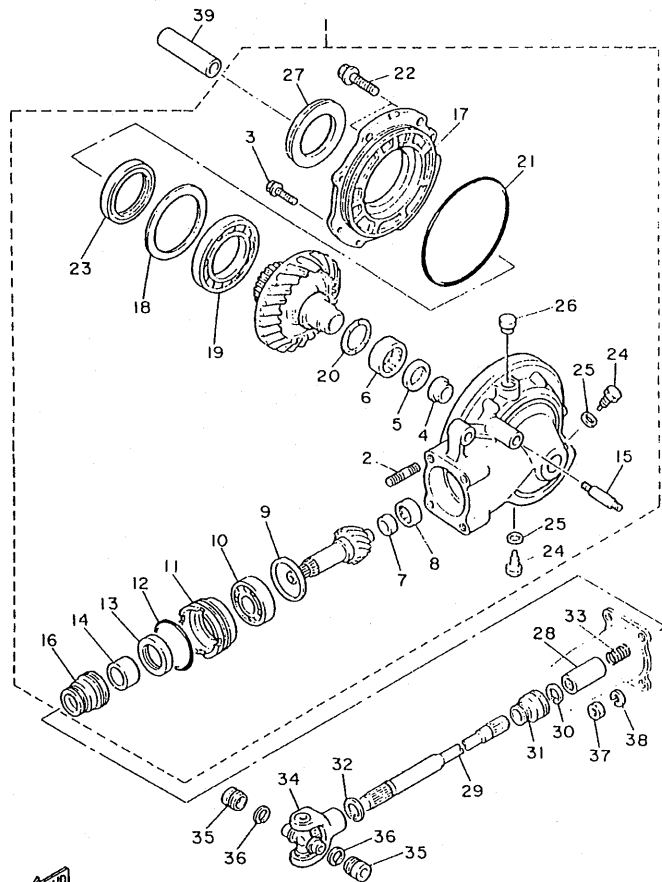

2JV171-7230

REF. NO.	CODIGO NO.	DESCRIPCION	4YHB			OBSERVACION
1	2NT-46101-00	CAJA ENGRANAJE EJE TRAS COMPL	1			
2	90116-10428	.ESPARRAGO	4			
3	90119-08126	.TORNILLO CON ARANDELA	6			
4	22U-46153-00	.COLLAR DE GUIA	1			
5	93101-30084	.SELLO ACEITE	1			
6	93311-43729	.COJINETE	1			
7	2H7-46122-00	.CARRERA INTERIOR	1			
8	93317-41510	.COJINETE	1			
9	1J7-17537-Y0-30	.CUNA DE EMPUJE (0.30T)	1			UR
	1J7-17537-Y0-40	.CUNA DE EMPUJE (0.40T)	1			UR
	1J7-17537-Y0-50	.CUNA DE EMPUJE (0.50T)	1			UR
10	93306-30539	.COJINETE	1			
11	4H7-46125-00	.RETEN DE COJINETE	1			
12	93210-60426	.ANILLO O	1			
13	93101-38098	.SELLO ACEITE	1			
14	90387-256G9	.CASQUILLO CON VALONA	1			
15	90116-10249	.ESPARRAGO	1			
16	22U-46136-00	.SELLO 1	1			
17	22U-46152-00	.CAJA DE COJINETE	1			
18	22U-46117-00-25	.CUNA ENGRANAJE DE ANILLO	1			UR
	22U-46117-00-30	.CUNA ENGRANAJE DE ANILLO	1			UR
	22U-46117-00-40	.CUNA ENGRANAJE DE ANILLO	1			UR
19	93316-01301	.COJINETE	1			
20	22U-46118-00-12	.ARANDELA DE EMPUJE (1.2T)	1			UR
	22U-46118-00-14	.ARANDELA DE EMPUJE (1.4T)	1			UR
	22U-46118-00-16	.ARANDELA DE EMPUJE (1.6T)	1			UR
	22U-46118-00-18	.ARANDELA DE EMPUJE (1.8T)	1			UR

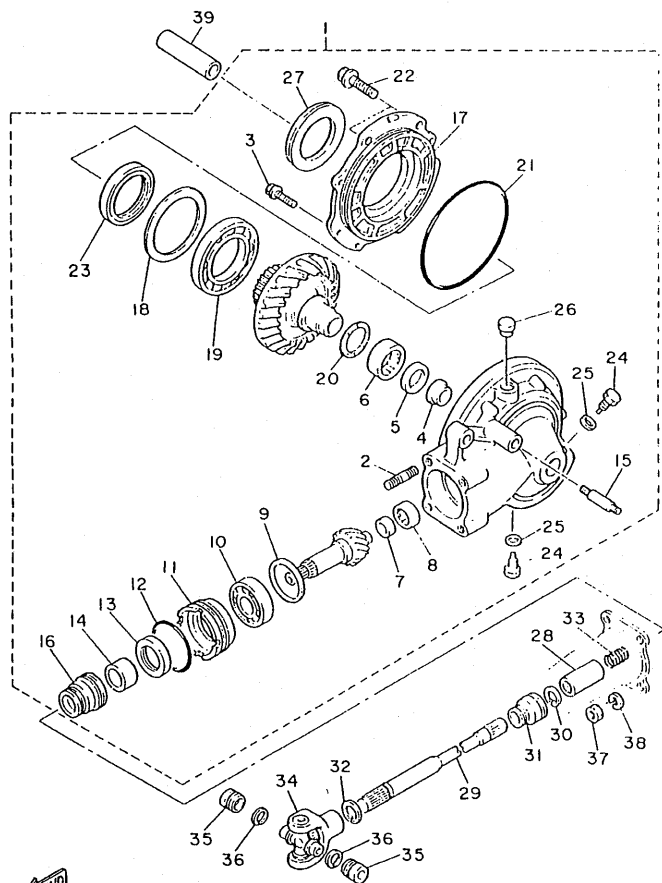

2JV171-7230

FIG. 23 EJE DE TRACCION

REF. NO.	CODIGO NO.	DESCRIPCION	4YHB			OBSERVACION
20	22U-46118-00-20	.ARANDELA DE EMPUJE (2.0T)	1			UR
21	93211-39569	.ANILLO O	1			
22	90105-10285	.TORNILLO CON ARANDELA	2			
23	93102-65277	.SELLO ACEITE	1			
24	90340-14009	.TORNILLO, DE DRENAJE	2			
25	214-11198-01	.EMPAQUE	2			
26	2H7-17590-00	.RESPIRADERO COMPLETO	1			
27	1J7-25319-01	.SELLO DE MASA PARA POLVO	1			
28	22U-46123-00	ACOPLAMIENTO DE ENGRANAJE	1			
29	2GV-46172-00	EJE DE TRACCION	1			
30	93440-19112	BOLA	1			
31	22U-46137-00	SELLO 2	1			
32	93410-22039	BOLA	1			
33	90501-15722	RESORTE DE COMPRESION	1			
34	4X7-46180-00	JUNTA TRASNSVERSAL COMPLETA	1			
35	93311-21044	COJINETE	2			
36	93440-20088	BOLA	2			
37	95314-10600	TUERCA	4			
38	92903-10100	ARANDELA	4			
39	90387-156G8	CASQUILLO CON VALONA	1			

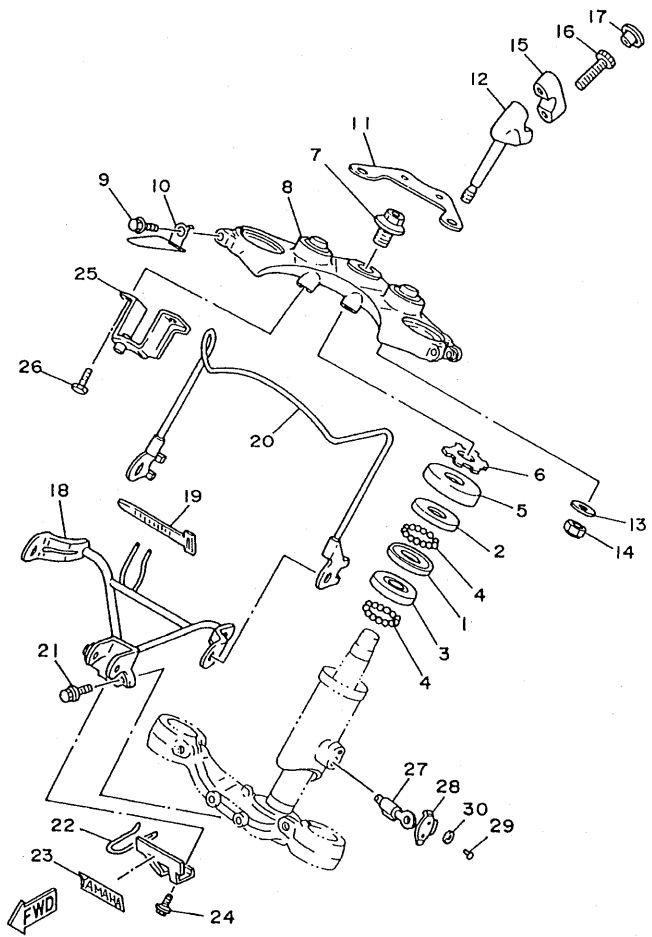

4KU8332-5240

FIG. 24 DIRECCION

REF. NO.	CODIGO NO.	DESCRIPCION	4YHIB			OBSERVACION
1	156-23412-00	PISTA DE BOLAS 2	1			
2	183-23411-00	PISTA DE BOLAS 1	1			
3	183-23412-00	PISTA DE BOLAS 2	1			
4	93501-04011	BOLA	38			
5	136-23415-00	CUBIERTA DE PISTA DE BOLAS 1	1			
6	90179-25033	TUERCA	1			
7	90105-14102	TORNILLO CON ARANDELA	1			
8	2GV-W2341-00-38	FIJADOR DE MANIJA	1			CLP
9	95024-08040	PERNO, DE BRIDA	2			
10	3JC-23317-00	SOSTEN DE CABLE	1			
11	2GV-2317F-00	FUCO SOPORTE COMPL	1			
12	42X-23442-00-38	SOPORTE DE MANUBRIO INFERIOR	2			CLP
13	90201-10141	ARANDELA PLANA	2			
14	95607-10100	TUERCA AUTOBLOCANTE	2			
15	4H7-23441-00-38	SOPORTE DE MANUBRIO	2			CLP
16	91314-08030	PERNO	4			
17	90338-08163	TAPON	4			
18	2GV-23174-01	SOPORTE DEL FARO DELANTERO	1			
19	3TB-83936-00	BANDA DE CABLE DE INTERRUPTOR	1			
20	2NT-23164-00	SOPORTE DE GUARDALUZ	1			
21	95027-06020	PERNO, DE BRIDA	2			
22	2GV-2317M-00	APOYO 3	1			
23	3WF-2153E-40	EMBLEMA, YAMAHA	1			
24	95024-06008	PERNO, DE BRIDA	1			
25	2GV-2317E-00	SOPORTE	1			
26	91317-06016	PERNO	2			
27	*	CERRADURA DE DIRECCION COMPL.	1			LM

D7

FIG. 24 DIRECCION

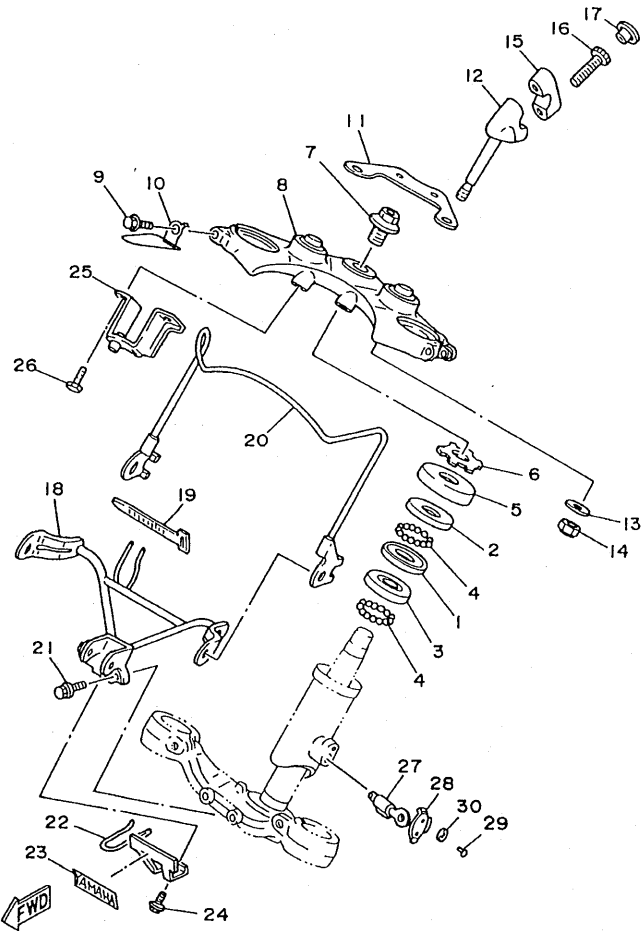

4KU8332-5240

REF. NO.	CODIGO NO.	DESCRIPCION	4Y/HB			OBSERVACION
28	134-23484-10	TAPA DE CERRADURA DE MANUBRIO	1			
29	90269-04003	REMACHE	1			
30	90208-04029	ARANDELA DE RESORTE CONICO	1			

FIG. 25 HORQUILLA DELANTERA

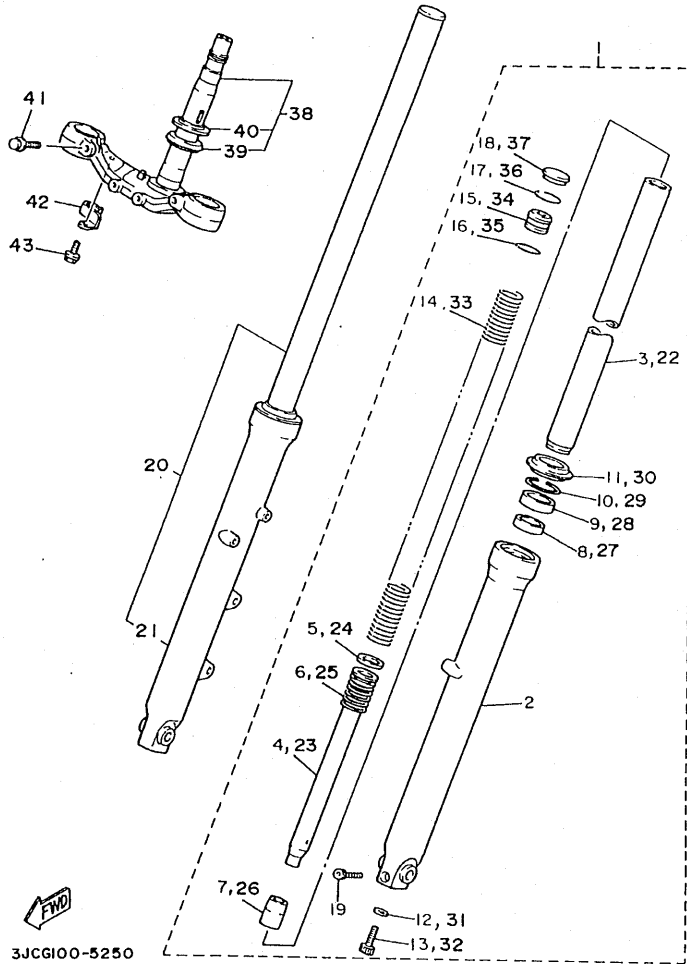

3JCG100-5250

REF. NO.	CODIGO NO.	DESCRIPCION	4YHB				OBSERVACION
1	4KU-23102-01	HORQUILLA DELANTERA COMPL.(MI)	1				
2	3JB-23126-11	.TUBO EXTERIOR 1	1				
3	2GV-23110-01	.TUBO INTERIOR COMPLETO 1	1				
4	2GV-23171-01	.PISTON HORQUILLA DELANT.	1				
5	1GU-23157-00	.ANILLO DEL PISTON	1				
6	1GU-23151-00	.RESORTE DE REBOTE	1				
7	1GU-23173-00	.VASTAGO AHUSADO	1				
8	2GV-23125-00	.METAL CORREDIZO 1	1				
9	2AJ-23145-00	.RETEN DE ACEITE	1				
10	1HX-23156-00	.PRESILLA DEL RETEN DE ACEITE	1				
11	2GV-23144-00	.GUARDAPOLVO	1				
12	90201-081E6	.ARANDELA PLANA	1				
13	91317-08025	.PERNO	1				
14	2GV-23141-00	.RESORTE HORQUILLA DELANT.	1				
15	1HX-23111-00	.TAPON	1				
16	93210-24709	.ANILLO O	1				
17	93450-32116	.BOLA	1				
18	1HX-23154-00	.TAPON TUBO INTERIOR	1				
19	91314-08035	.PERNO	1				
20	4KU-23103-01	HORQUILLA DELANTERA COMPL.(MD)	1				
21	3JB-23136-11	.TUBO EXTERIOR (DER.)	1				
22	2GV-23110-01	.TUBO INTERIOR COMPLETO 1	1				
23	2GV-23171-01	.PISTON HORQUILLA DELANT.	1				
24	1GU-23157-00	.ANILLO DEL PISTON	1				
25	1GU-23151-00	.RESORTE DE REBOTE	1				
26	1GU-23173-00	.VASTAGO AHUSADO	1				
27	2GV-23125-00	.METAL CORREDIZO 1	1				

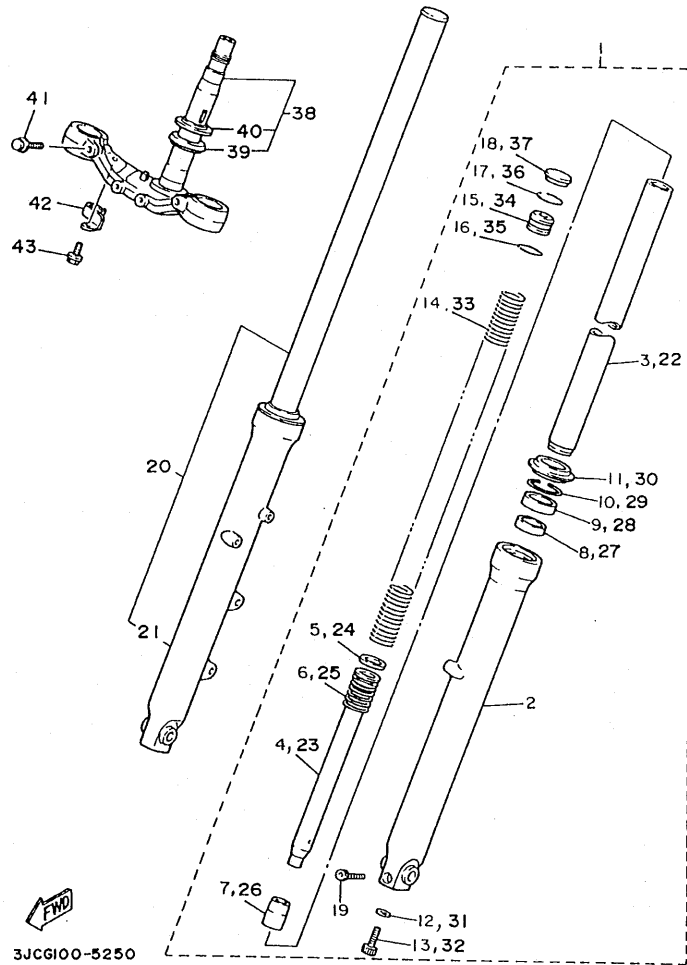

3JCG100-5250

FIG. 25 HORQUILLA DELANTERA

REF. NO.	CODIGO NO.	DESCRIPCION	4YHB				OBSERVACION
28	2AJ-23145-00	.RETEN DE ACEITE	1				
29	1HX-23156-00	.PRESILLA DEL RETEN DE ACEITE	1				
30	2GV-23144-00	.GUARDAPOLVO	1				
31	90201-081E6	.ARANDELA PLANA	1				
32	91317-08025	.PERNO	1				
33	2GV-23141-00	.RESORTE HORQUILLA DELANT.	1				
34	1HX-23111-00	.TAPON	1				
35	93210-24709	.ANILLO O	1				
36	93450-32116	.BOLA	1				
37	1HX-23154-00	.TAPON TUBO INTERIOR	1				
38	3BR-23340-00	PLATINA INFERIOR COMPLETA	1				
39	164-23462-00	.RETEN DE DIRECCION	1				
40	156-23411-00	.PISTA DE BOLAS 1	1				
41	90105-12353	TORNILLO CON ARANDELA	2				
42	3JB-25886-00	SOPORTE DE MANGUERA FRENO	1				
43	95807-06010	TUERCA DE REBORDE	1				

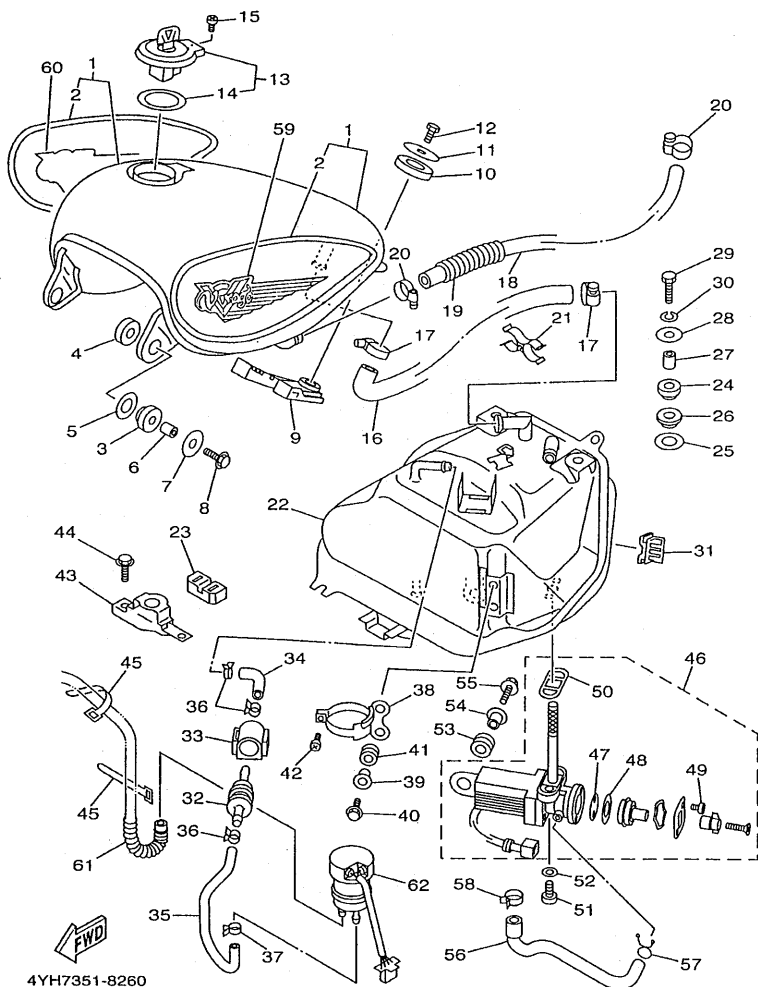

4YH7351-8260

FIG. 26 DEPOSITO DE COMBUSTIBLE

REF. NO.	CODIGO NO.	DESCRIPCION	4YHB	OBSERVACION
1	3BR-Y2428-S0-2X	SUBDEPOSITO	1	UR URB/MRGD
	3BR-Y2428-X0-6X	SUBDEPOSITO	1	UR DCM8/NPW
	3BR-Y2428-V0-5X	SUBDEPOSITO	1	UR DYRM2/AVG
2	4KU-24240-71	.JUEGO DE CALCOMANIAS	1	UR PARA URB
	4KU-24240-90	.JUEGO DE CALCOMANIAS	1	UR PARA DCM8
	4KU-24240-80	.JUEGO DE CALCOMANIAS	1	UR PARA DYRM2
3	1FK-24182-00	AMORTIGUADOR DE MONTAJE 2	2	
4	1FK-24183-00	AMORTIGUADOR DE MONTAJE 3	2	
5	1FK-24186-00	ARANDELA ESPECIAL	2	
6	90387-062G5	CASQUILLO CON VALONA	2	
7	90201-066M2	ARANDELA PLANA	2	
8	95024-06025	PERNO, DE BRIDA	2	
9	3JB-24182-00	AMORTIGUADOR DE MONTAJE 2	1	
10	42X-24183-00	AMORTIGUADOR DE MONTAJE 3	1	
11	90201-08569	ARANDELA PLANA	1	
12	97007-08016	PERNO	1	
13	4X7-24602-04	TAPON COMPLETO	1	
14	4X7-24612-00	.EMPAQUE DE TAPA	1	
15	91317-05010	PERNO	1	
16	3JB-24316-00	TUBO 6	1	
17	90450-25037	BRIDA, MANGUERA	2	
18	3JB-24317-00	TUBO 7	1	
19	90501-101J4	RESORTE DE COMPRESION	1	
20	90450-22017	BRIDA, MANGUERA	2	
21	3JB-24135-00	GRAMPA 1	1	
22	3JB-24110-01-33	DEPOSITO DE COMBUSTIBLE COMP.	1	YB
23	2GV-24181-00	AMORTIGUADOR DE MONTAJE	1	

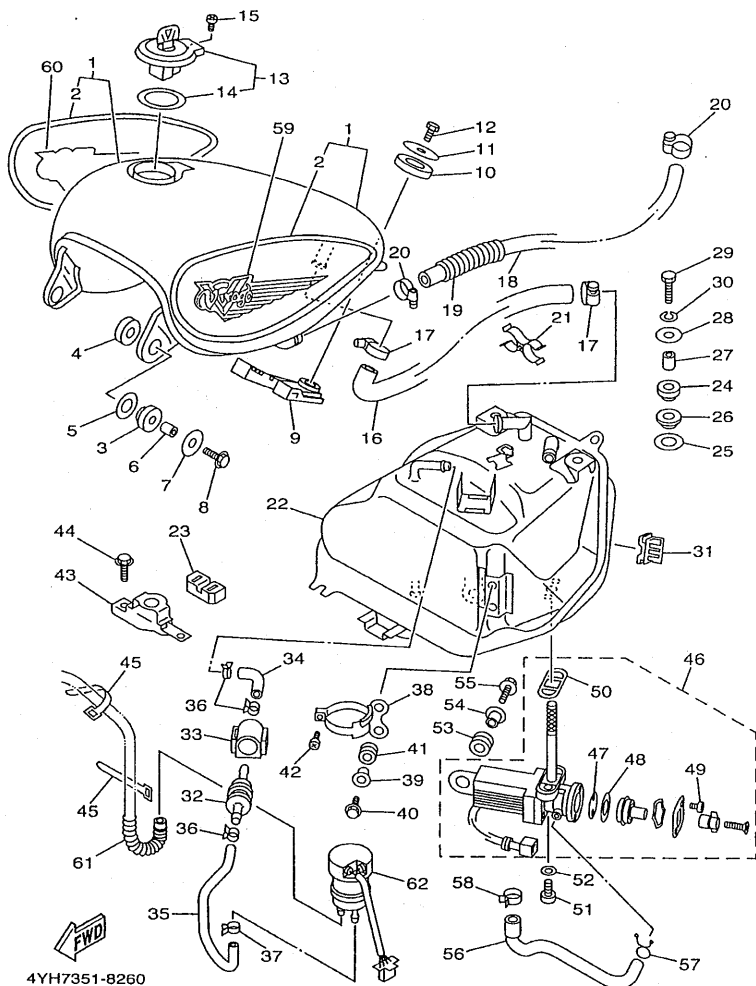

4YH7351-8260

FIG. 26 DEPOSITO DE COMBUSTIBLE

REF. NO.	CODIGO NO.	DESCRIPCION	4YHB			OBSERVACION
24	1FK-24182-00	AMORTIGUADOR DE MONTAJE 2	2			
25	1FK-24183-00	AMORTIGUADOR DE MONTAJE 3	2			
26	1FK-24186-00	ARANDELA ESPECIAL	2			
27	90387-062G5	CASQUILLO CON VALONA	2			
28	90201-065G8	ARANDELA PLANA	2			
29	97027-06030	PERNO	2			
30	92907-06100	ARANDELA	2			
31	2GV-24184-00	AMORTIGUADOR DE MONTAJE 4	2			
32	1FK-24560-00	FILTRO COMPLETO	1			
33	1FK-24566-00	SOPORTE DEL FILTRO	1			
34	2GV-24311-00	TUBO DE COMBUSTIBLE 1	1			
35	2GV-24312-00	TUBO 2	1			
36	90467-12053	PRESILLA	3			
37	90467-10135	PRESILLA	1			
38	2GV-24491-00	SOPORTE BOMBA COMBUSTIBLE	1			
39	90387-062L2	CASQUILLO CON VALONA	2			
40	95807-06016	TUERCA DE REBORDE	2			
41	90480-13163	TAPON	2			
42	98507-05016	TORNILLO DE CABEZA CON PLANA	1			
43	2GV-24191-00	SOPORTE DEPOSITO DE COMBUST.1	1			
44	90119-06123	TORNILLO CON ARANDELA	2			
45	437-83936-11	BANDA DE CABLE DE INTERRUPTOR	3			
46	3JB-24500-03	GRIFO DE COMBUSTIBLE 1	1			
47	3AJ-24523-00	.VALVULA	1			
48	3AJ-24534-00	.SELLO DE GRIFO	1			
49	98507-03008	.TORNILLO DE CABEZA CON PLANA	2			
50	4X8-24512-00	.EMPAQUE	1			

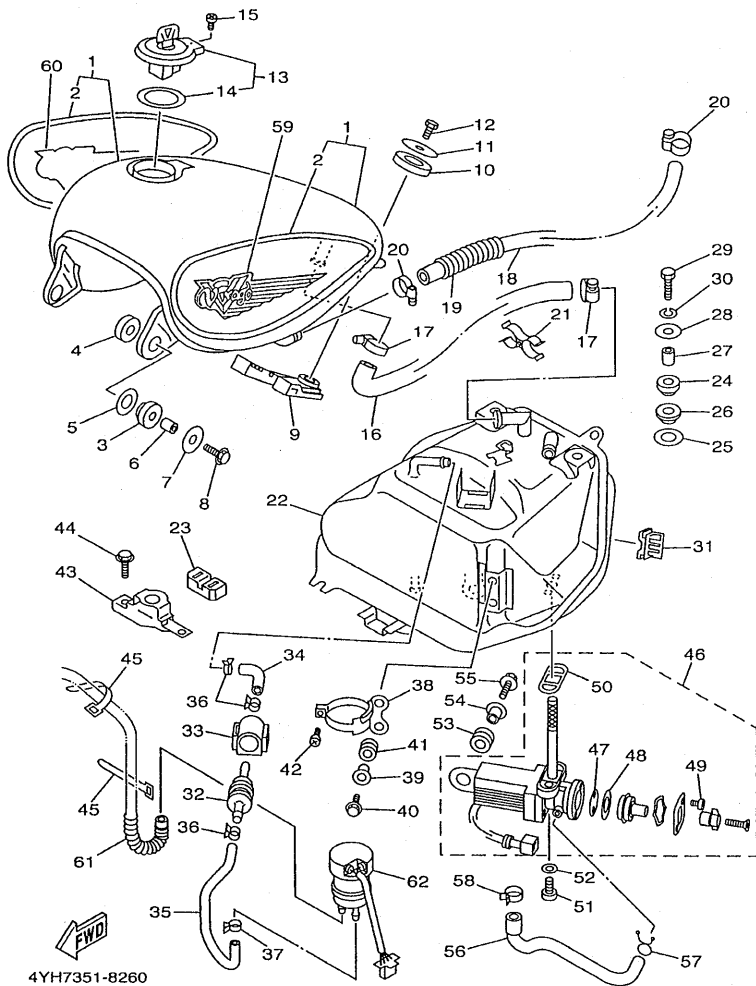

4YH7351-8260

FIG. 26 DEPOSITO DE COMBUSTIBLE

REF. NO.	CODIGO NO.	DESCRIPCION	4YHB			OBSERVACION
51	90149-06008	TORNILLO DE REGLAJE	2			
52	90202-05193	ARANDELA DE PLANA	2			
53	90480-14102	TAPON	1			
54	90387-063E6	CASQUILLO CON VALONA	1			
55	95807-06025	TUERCA DE REBORDE	1			
56	3JB-24314-00	TUBO 4	1			
57	90467-10008	PRESILLA	1			
58	90467-12053	PRESILLA	1			
59	4MC-24161-00	EMBLEMA 1	1			
60	4MC-24162-00	EMBLEMA 2	1			
61	90501-100F8	RESORTE DE COMPRESION	1			
62	2GV-13907-00	BOMBA DE COMBUSTIBLE COMPLETA	1			

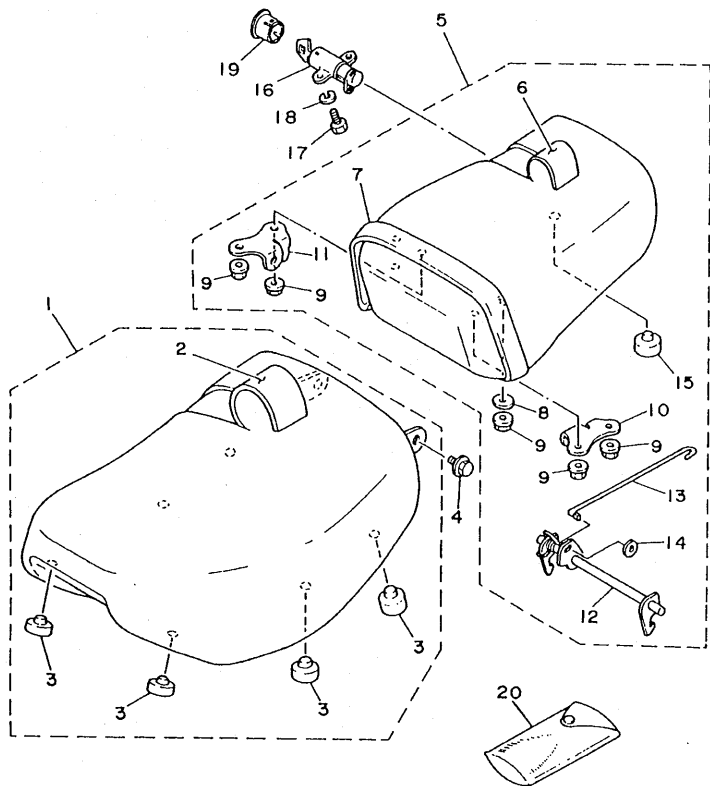

FIG. 27 ASIENTO

REF. NO.	CODIGO NO.	DESCRIPCION	4YHB				OBSERVACION
1	3JB-24710-10	ASIENTO SIMPLE COMPLETO	1				
2	3JB-24711-10	.CUBIERTA DE ASIENTO SIMPLE	1				
3	18A-24724-00	.AMORTIGUADOR DE ASIENTO	6				
4	95807-06012	TUERCA DE REBORDE	2				
5	3JB-24750-10	ASIENTO TANDEM COMPLETO	1				
6	3JB-24751-10	.CUBIERTA DE ASIENTO TANDEM	1				
7	3JB-24734-10	.BANDA DE ASIENTO	1				
8	90201-06765	.ARANDELA PLANA	2				
9	95707-06500	.TUERCA DE BRIDA	6				
10	3JB-24718-00	.SOPORTE DE ASIENTO	1				
11	3JB-24728-00	.SOPORTE DE ASIENTO	1				
12	3JB-24776-00	.PALANCA DE ASIENTO	1				
13	3JB-2478F-00	.VARILLA, CONECTORA	1				
14	92907-03200	.ARANDELA	1				
15	18A-24724-00	.AMORTIGUADOR DE ASIENTO	1				
16	47X-24705-00	CIERRE DE SILLIN COMPLETO	1				
17	97007-06014	PERNO	2				
18	92907-06100	ARANDELA	2				
19	51Y-24796-00	CUBIERTA	1				
20	2GV-28100-00	JUEGO DE HERRAMIENTAS	1				



3JCG100-5280

FIG. 28 RUEDA DELANTERA

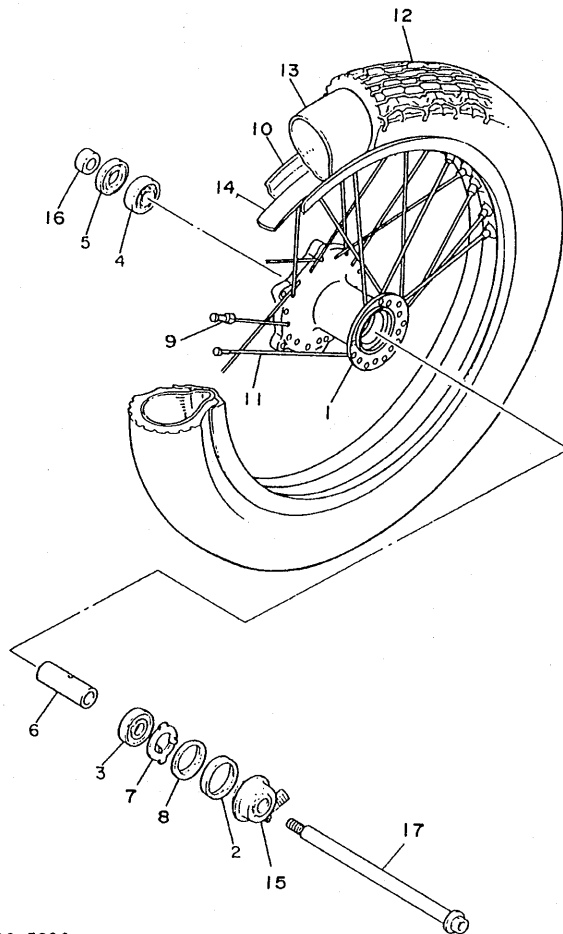

REF. NO.	CODIGO NO.	DESCRIPCION	4YHB				OBSERVACION
1	4KU-25111-00	MASA DELANTERA	1				
2	93105-45017	SELLO ACEITE	1				
3	93306-30319	COJINETE	1				
4	93306-30319	COJINETE	1				
5	93102-28022	SELLO ACEITE	1				
6	90560-17126	SEPARADOR	1				
7	341-25149-00	EMBRAGUE DEL CUENTAKMS	1				
8	341-25846-00	RETEN DEL EMBRAGUE	1				
9	5V4-25398-00	CONTRAPESO DE RUEDA	1				UN
10	94418-19543	ARO (1.85-19)	1				
11	3JB-25104-01	JUEGO DE RAYOS DELANTERO	1				
12	94130-197N0	NEUMATICO(3.00S19 4PR F14G)	1				UR DUNLOP
	94130-197N1	NEUMATICO(3.00S19 4PR L303A)	1				UR BRIDGESTONE
13	94227-19177	TUBO (2.75-19)	1				DUNLOP
14	94325-19115	BANDA DE ARO (2.50-19)	1				DUNLOP
15	4TX-25190-10	UNIDAD DE ENGRANAJE COMPLETA	1				
16	90387-177R1	CASQUILLO CON VALONA	1				
17	2GV-25181-00	EJE DE LA RUEDA	1				

FIG. 29 CALIBRE FRENO DELANTERA

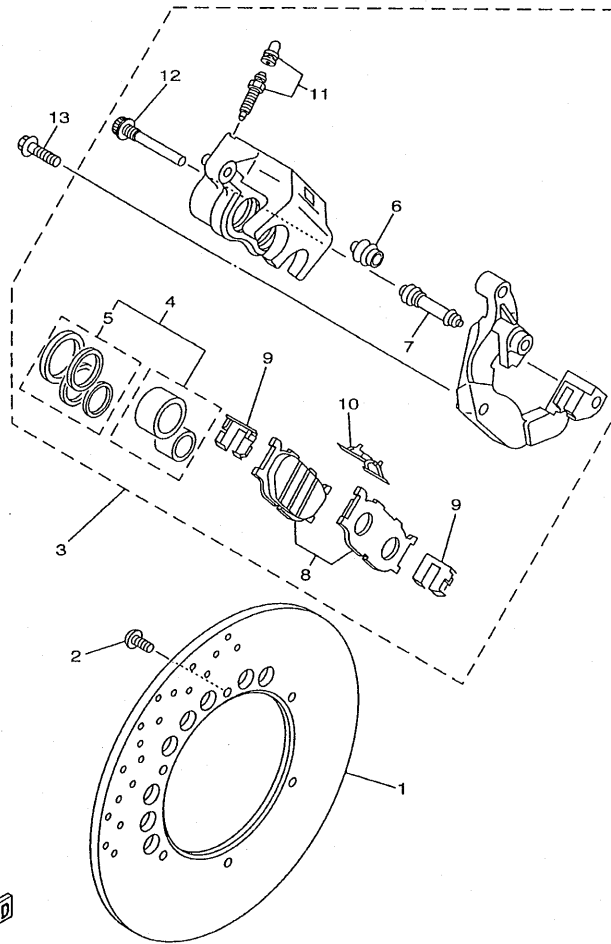

4YH9300-9300

REF. NO.	CODIGO NO.	DESCRIPCION	4YHB			OBSERVACION
1	3JB-2582U-01	DISCO DE FRENO (DERECO)	1			
2	90109-081F0	PERNO	6			
3	3JB-2580U-11	CALIBRE COMPLETO (DERECO)	1			
4	3JB-W0057-00	.PISTON COMPLETO PINZA	1			
5	3JB-W0047-00	..JUEGO DE RETENES DE PINZA	1			
6	5R2-25937-00	.FUNDA	1			
7	3YX-25937-00	.FUNDA	1			
8	4BP-W0045-00	.JUEGO DE COJIN DE FRENO	1			
9	3YX-25919-00	.SOPORTE DE PASTILLAS	2			
10	3YX-25929-00	.RESORTE PLACA, COJIN DE FRENO	1			
11	51L-W0048-00	.CJTO TORNILLO DE PURGA	1			
12	3YX-25926-00	.PERNO	1			
13	90105-10638	TORNILLO CON ARANDELA	2			

FIG. 30 RUEDA TRASERA

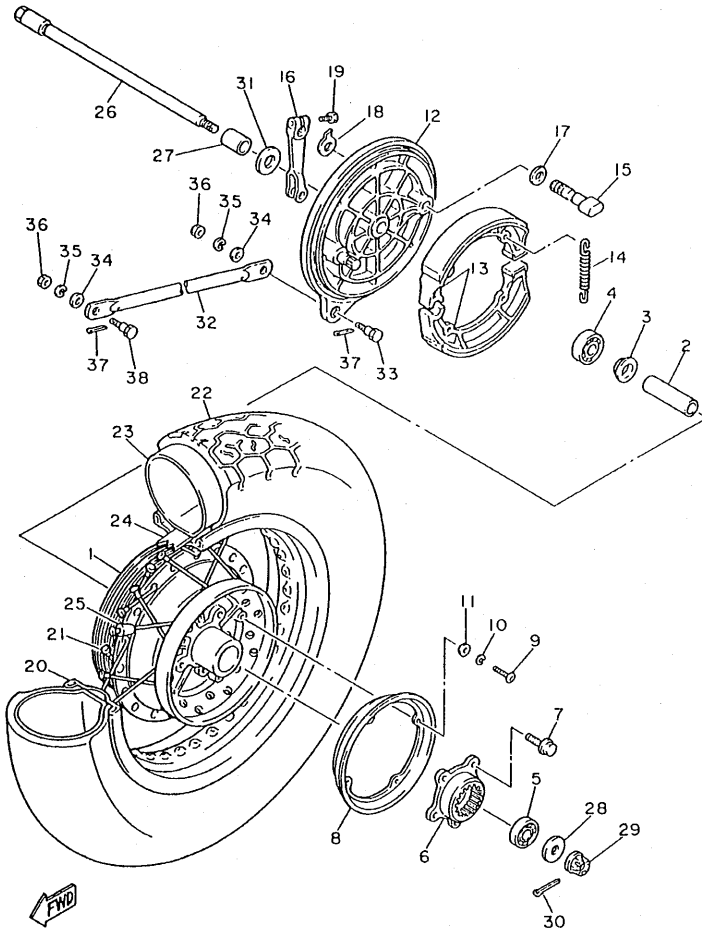

2GV110-7300

REF. NO.	CODIGO NO.	DESCRIPCION	4YHB		OBSERVACION
1	2GV-25311-00-35	MASA TRASERA	1		SL
2	2GV-25317-00	ESPACIADOR DE COJINETE	1		
3	2GV-25315-00	SEPARADOR	1		
4	93306-30209	COJINETE	1		
5	93306-30202	COJINETE	1		
6	2GV-25366-00	EMBRAGUE DE MASA	1		
7	90105-10200	TORNILLO CON ARANDELA	5		
8	2GV-25319-00	SELLO DE MASA PARA POLVO	1		
9	98507-05012	TORNILLO DE CABEZA CON PLANA	4		
10	92907-05100	ARANDELA	4		
11	92907-05600	ARANDELA	4		
12	2NT-25321-00	PLACA DE ZAPATA DE FRENO	1		
13	3DR-W2536-00	JUEGO DE ZAPATA DE FRENO	1		
14	90507-20002	RESORTE DE TENSION	2		
15	4H7-25351-00	ARBOL DE LEVAS	1		
16	214-25355-00	PALANCA DE ARBOL DE LEVAS	1		
17	90201-14577	ARANDELA PLANA	1		
18	4H7-2533A-02	PLACA INDICADOR	1		
19	90101-06764	TORNILLO	1		
20	94430-15544	ARO	1		
21	2GV-25304-01	JUEGO DE RAYOS TRASEROS	1		
22	94114-156U1	NEUMATICO(140/90-15M/C70S K425	1		UR DUNLOP
	94114-156U2	NEUMATICO(140/90-15M/C70S G508	1		UR BRIDGESTONE
23	94214-15223	TUBO (140/90-15)	1		BRIDGESTONE
24	94330-15134	BANDA DE ARO (3.00-15)	1		BRIDGESTONE
25	5V4-25398-00	CONTRAPESO DE RUEDA	1		UN
26	2GV-25381-00	EJE DE RUEDA	1		

FIG. 31 MANUBRIO. CABLE

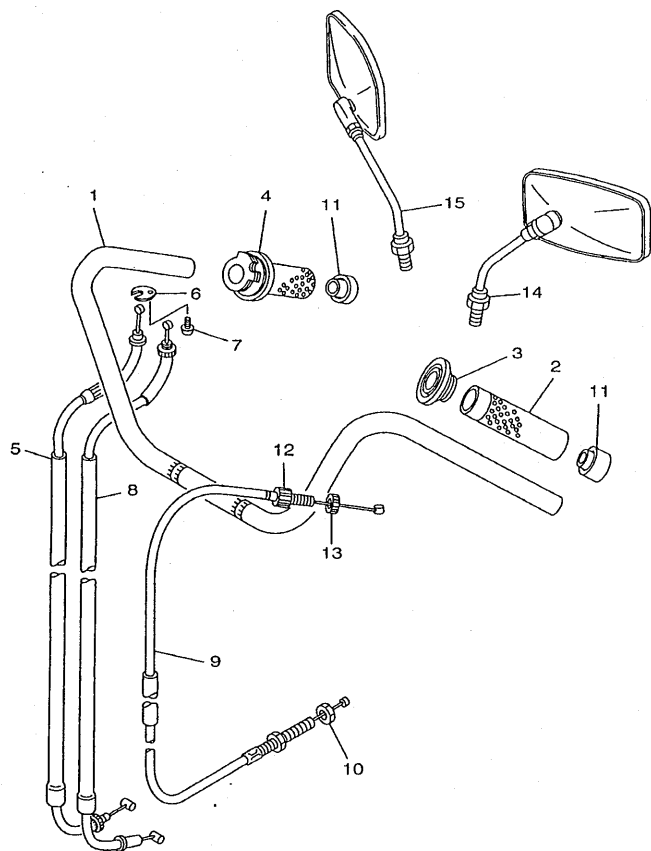

4YN3100-8320

REF. NO.	CODIGO NO.	DESCRIPCION	4YHB				OBSERVACION
1	2GV-26111-11	MANUBRIO	1				
2	3JB-26241-00	EMPUNADURA (MI)	1				
3	3JB-26273-00	ROTOR	1				
4	3JB-26240-00	EMPUNADURA COMPLETA	1				
5	3JC-26311-00	CABLE DE ACELERADOR 1	1				
6	5H0-26393-00	SOPORTE	1				
7	98507-05008	TORNILLO DE CABEZA CON PLANA	1				
8	3JC-26312-00	CABLE DE ACELERADOR 2	1				
9	3JB-26335-20	CABLE DE EMBRAGUE	1				
10	95304-08700	TUERCA	1				
11	3JB-2628J-00	TAPA EMPUNADURA	2				
12	90123-08046	PERNO	1				
13	90179-08148	TUERCA	1				
14	4H7-26290-A1	ESPEJO COMPLETO (DERECHO)	1				
15	4H7-26290-E1	ESPEJO COMPLETO (DERECHO)	1				

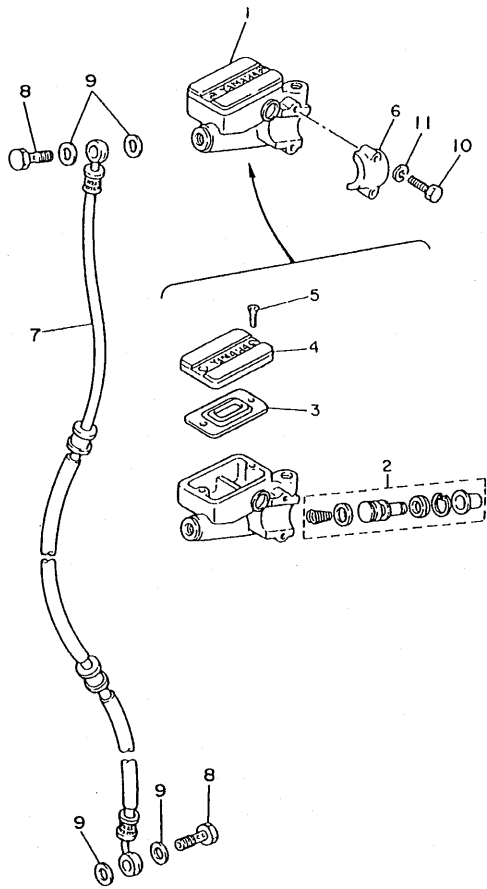

3JCG100-5330

FIG. 32 CILINDRO MAESTRO DELANTERO

REF. NO.	CODIGO NO.	DESCRIPCION	4YHB				OBSERVACION
1	4H7-25850-02	CILINDRO MAESTRO COMPLETO	1				
2	4H7-W0041-00	.JUEGO DE CILINDRO MAESTRO	1				
3	4L0-25854-00	.DIAFRAGMA TANQUE RESERVA	1				
4	4H7-25852-00	.TAPA DE TANQUE DE RESERVA	1				
5	98706-04012	.TORNILLO DE CABEZA PLANA	2				
6	4L0-25867-00	SOPORTE DE CILINDRO MAESTRO	1				
7	4KU-25872-00	MANGUERA DE FRENO 1	1				
8	90401-10159	PERNO DE UNION	2				
9	90201-10118	ARANDELA PLANA	4				
10	97007-06025	PERNO	2				
11	92907-06600	ARANDELA	2				

FIG. 33 SOPORTE. APOYAPIE

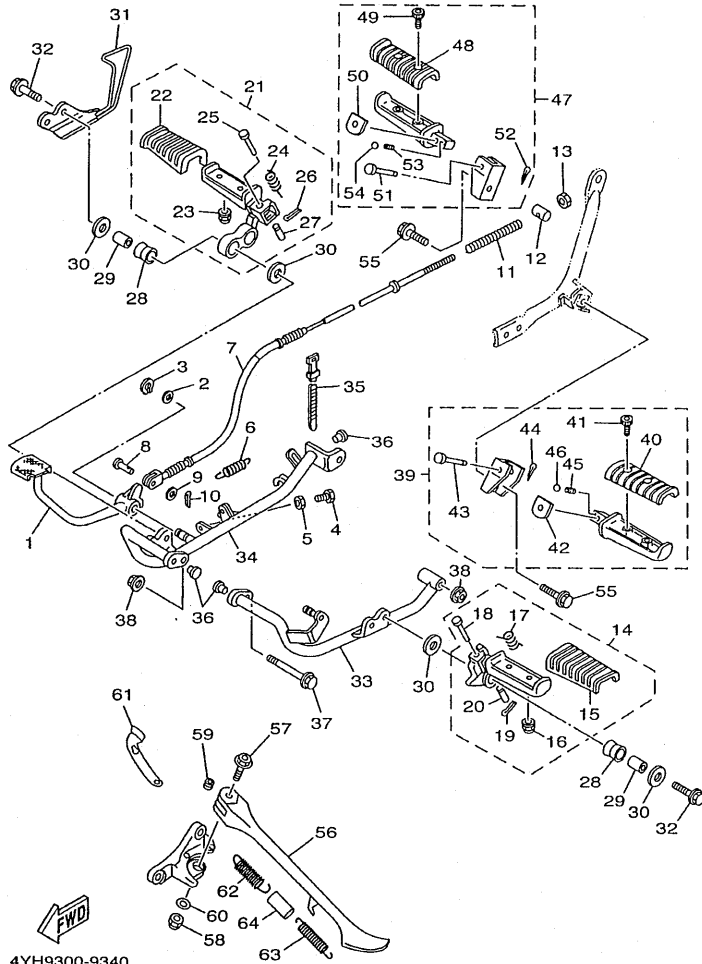

REF. NO.	CODIGO NO.	DESCRIPCION	4YHB			OBSERVACION
1	2GV-27211-00-93	PEDAL DE FRENO	1			CM
2	90201-152L1	ARANDELA PLANA	1			
3	99009-15400	PRESILLA REDONDA	1			
4	90101-06288	TORNILLO	1			
5	95307-06700	TUERCA	1			
6	90506-20380	RESORTE DE TENSION	1			
7	2GV-26351-00	CABLE DE FRENO	1			
8	91701-06022	PASADOR DE ABRAZADERA	1			
9	92907-06200	ARANDELA	1			
10	91401-20012	PASADOR DE CHAVETA	1			
11	90501-10245	RESORTE DE COMPRESION	1			
12	90249-12008	PASADOR	1			
13	90179-06411	TUERCA	1			
14	1RM-27410-00-93	APOYAPIE DELANTERO (MI)	1			CM
15	1NH-27413-00	.CUBIERTA DE APOYAPIE	1			
16	95607-06100	.TUERCA AUTOBLOCANTE	2			
17	90508-18696	.RESORTE DE TORSION	1			
18	90240-08084	.PASADOR CON HOYO	1			
19	91401-25015	.PASADOR DE CHAVETA	1			
20	90387-087K5	.CASQUILLO CON VALONA	1			
21	1RM-27420-00-93	APOYAPIE DELANTERO (MD)	1			CM
22	1NH-27413-00	.CUBIERTA DE APOYAPIE	1			
23	95607-06100	.TUERCA AUTOBLOCANTE	2			
24	90508-18696	.RESORTE DE TORSION	1			
25	90240-08084	.PASADOR CON HOYO	1			
26	91401-25015	.PASADOR DE CHAVETA	1			
27	90387-087K5	.CASQUILLO CON VALONA	1			

FIG. 33 SOPORTE. APOYAPIE

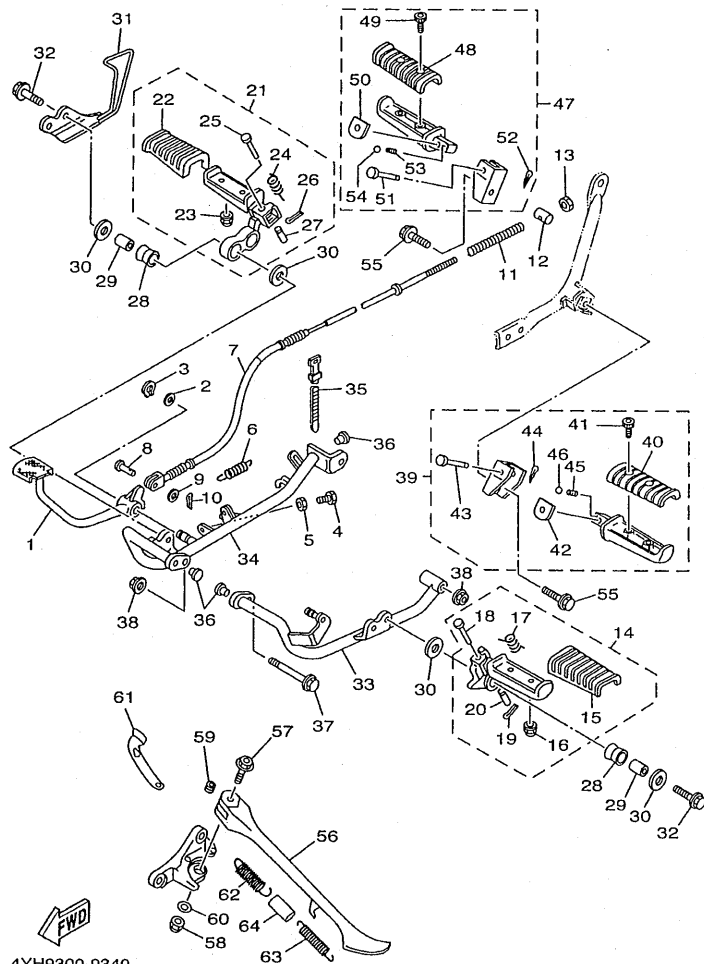

4YH9300-9340

REF. NO.	CODIGO NO.	DESCRIPCION	4YHB				OBSERVACION
28	4X7-27414-00	AMORTIGUADOR DE APOYAPIE	4				
29	90387-107A7	CASQUILLO CON VALONA	4				
30	90201-100A1	ARANDELA PLANA	6				
31	2GV-27491-00	PROTECTOR	1				
32	90109-100G0	PERNO	4				
33	2GV-27471-02	BARRA, DE APOYAPIE 1	1				
34	2GV-27472-02	BARRA, DE APOYAPIE 2	1				
35	90465-13152	BRIDA	1				
36	90338-09161	TAPON	3				
37	90105-10312	TORNILLO CON ARANDELA	1				
38	95704-10500	TUERCA DE BRIDA	2				
39	2NT-27430-01	APOYAPIE POSTERIOR COMPLETO 1	1				
40	1NH-27433-00	.CUBIERTA APOYAPIE TRASERO	1				
41	92016-06012	.PERNO	2				
42	2NT-27437-00	.ARANDELA ESPECIAL	1				
43	91701-06032	.PASADOR DE ABRAZADERA	1				
44	91401-20015	.PASADOR DE CHAVETA	1				
45	90501-12743	.RESORTE DE COMPRESION	1				
46	93501-04011	.BOLA	1				
47	2NT-27440-01	APOYAPIE POSTERIOR COMPLETO 2	1				
48	1NH-27433-00	.CUBIERTA APOYAPIE TRASERO	1				
49	92016-06012	.PERNO	2				
50	2NT-27437-00	.ARANDELA ESPECIAL	1				
51	91701-06032	.PASADOR DE ABRAZADERA	1				
52	91401-20015	.PASADOR DE CHAVETA	1				
53	90501-12743	.RESORTE DE COMPRESION	1				
54	93501-04011	.BOLA	1				

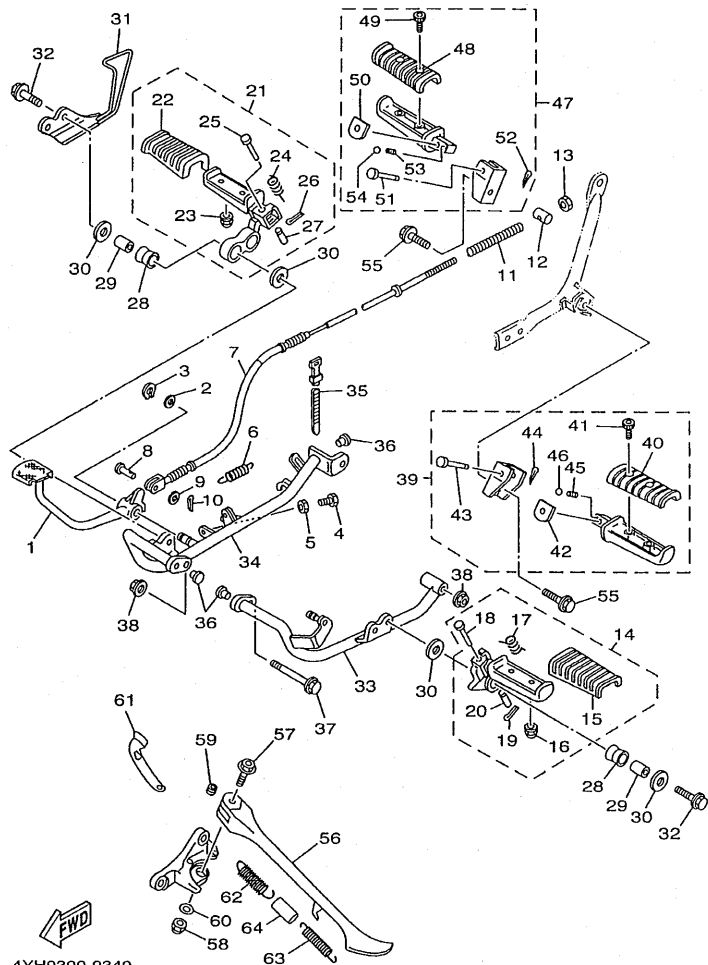

4YH9300-9340

FIG. 33 SOPORTE. APOYAPIE

REF. NO.	CODIGO NO.	DESCRIPCION	4YHB	OBSERVACION
55	95804-10016	TUERCA DE REBORDE	2	
56	4KU-27311-12	PUNTAL LATERAL	1	
57	90105-10188	TORNILLO CON ARANDELA	1	
58	95617-10100	PERNO DE PUNTAL	1	
59	90387-1003G	CASQUILLO CON VALONA	1	
60	92907-10200	ARANDELA	1	
61	5H0-27315-00	CONEXION DE PUNTAL LATERAL	1	
62	90506-29507	RESORTE DE TENSION	1	
63	90506-23490	RESORTE DE TENSION	1	
64	90445-16641	TUBO	1	

FIG. 35 LUZ DE DESTELLADOR

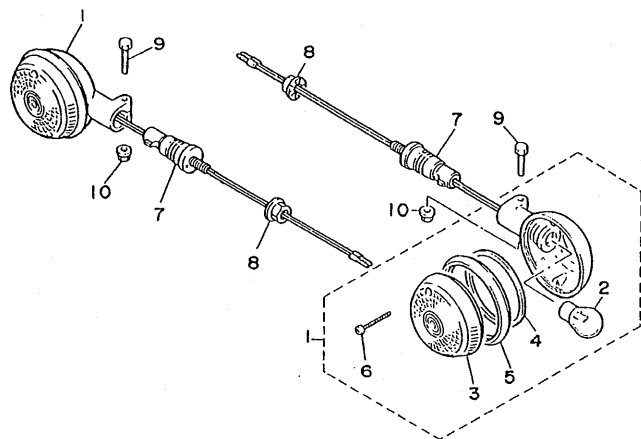
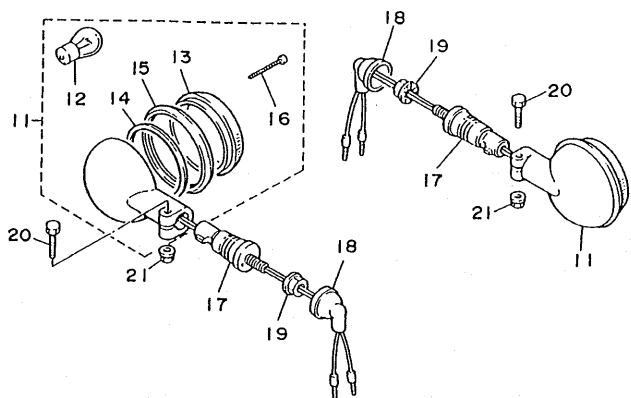

3BMF361-7350

REF. NO.	CODIGO NO.	DESCRIPCION	4Y/HB	OBSERVACION
1	3LS-83310-00	DESTELLADOR DE LUZ DELANT.	2	Go to P/N: PE0-MC-040084
2	2AE-83311-00	.BOMBILLA DE DESTELLADOR	1	Go to P/N: PE0-MC-040084
3	42X-83312-00	.LENTE DE DESTELLADOR	1	Go to P/N: PE0-MC-040084
4	42X-83313-00	.EMPAQUE DE LENTE DESTELLADOR	1	Go to P/N: PE0-MC-040084
5	42X-83363-00	.LENTES	1	Go to P/N: PE0-MC-040084
6	57M-83358-00	.TORNILLO ESPECIAL	2	Go to P/N: PE0-MC-040084
7	1AA-83318-00	SOPORTE DE DESTELLADOR 1	2	
8	95307-12600	TUERCA	2	
9	95024-06030	PERNO, DE BRIDA	2	
10	95704-06500	TUERCA DE BRIDA	2	
11	4YH-83330-00	DESTELLADOR DE LUZ TRAS.COMPL.	2	Go to P/N: PE0-MC-040084
12	2AE-83311-00	.BOMBILLA DE DESTELLADOR	1	Go to P/N: PE0-MC-040084
13	2AE-83312-00	.LENTE DE DESTELLADOR	1	Go to P/N: PE0-MC-040084
14	42X-83313-00	.EMPAQUE DE LENTE DESTELLADOR	1	Go to P/N: PE0-MC-040084
15	42X-83363-00	.LENTES	1	Go to P/N: PE0-MC-040084
16	57M-83358-00	.TORNILLO ESPECIAL	2	Go to P/N: PE0-MC-040084
17	1AA-83318-00	SOPORTE DE DESTELLADOR 1	2	
18	18G-83365-00	TAPON	2	
19	95307-12600	TUERCA	2	
20	95024-06030	PERNO, DE BRIDA	2	
21	95704-06500	TUERCA DE BRIDA	2	

PARTS NEWS

News No. M/C-04084 1/4

Date: August, 6, 2004

Signature: K. Otsuka

Model	XV535
Subject	PARTS CATALOGUE CORRECTIONS
CATALOGUE NO.	See the "List of Models and CATALOGUE No's below."

Please make the following corrections to your parts catalogue.

1. LIST CORRECTION FLASHER LIGHT

The old front flasher light assy 1 [3LS-83310-00...2piece] => left side/light side...1 piece each It becomes setting change.

OLD Ref.No.	NEW Ref.No.	OLD P/No.	NEW P/No.	PART NAME	Q'TY	REMARKS	*1
1	←	3LS-83310-00	3LS-83310-01	FRONT FLASHER LIGHT ASSY 1	2=>1	*Part number revision (FOR LEFT)	B
2	←	2AE-83311-00	←	. BULB, FLASHER (12V-21W)	1	*No part number change	
3	←	42X-83312-00	42X-83312-10	. LENS, FLASHER	1	*Part number revision	○
4	←	42X-83313-00	1D6-83313-00	. GASKET, FLASHER LENS	1		B ○
5	←	42X-83363-00	1D6-83363-00	. LENS, RIM	1		B ○
6	←	57M-83358-00	←	. SCREW, SPECIAL	2	*No part number change	

1	22	3LS-83310-00	3LS-83320-01	FRONT FLASHER LIGHT ASSY 2	1	*Part number revision (FOR RIGHT)	B
2	23	2AE-83311-00	←	. BULB, FLASHER (12V-21W)	1	*No part number change	
3	24	42X-83312-00	42X-83312-20	. LENS, FLASHER	1	*Part number revision	○
4	25	42X-83313-00	1D6-83313-00	. GASKET, FLASHER LENS	1		B ○
5	26	42X-83363-00	1D6-83363-10	. LENS, RIM	1		B ○
6	27	57M-83358-00	←	. SCREW, SPECIAL	2	*No part number change	

*1: Interchangeability

A	Old Parts	→	Old Parts
	New Parts	→	New Parts
B	Old Parts	→	Old Parts
	New Parts	→	New Parts
C	Old Parts	→	Old Parts
	New Parts	→	New Parts
○	These parts are interchangeable with a set		

Parts
Manager
Check

Service
Manager
Check

Parts
Manager
File

YAMAHA MOTOR CO.,LTD
2500 Shingai Iwata Shizuoka 438-8501.Japan
GLOBAL TECHNICAL PUBLICATION DIV.

PARTS NEWS

News No. M/C-04084 2/4

Date: August, 6, 2004

Signature: K. Otsuka

Model	XV535
Subject	PARTS CATALOGUE CORRECTIONS
CATALOGUE NO.	See the "List of Models and CATALOGUE No's below."

1. LIST CORRECTION FLASHER LIGHT

The old rear flasher light assy 1 [4YH-83330-00...2piece] => left side/light side...1 piece each It becomes setting change.

OLD Ref.No.	NEW Ref.No.	OLD P/No.	NEW P/No.	PART NAME	Q'TY	REMARKS	*1
11	←	4YH-83330-00	4YH-83330-01	REAR FLASHER LIGHT ASSY 1	2=>1	*Part number revision (FOR LEFT)	B
12	←	2AE-83311-00	←	. BULB, FLASHER (12V-21W)	1	*No part number change	
13	←	2AE-83312-00	2AE-83312-20	. LENS, FLASHER	-	*Part number revision	○
14	←	42X-83313-00	1D6-83313-00	. GASKET, FLASHER LENS	1		B ○
15	←	42X-83363-00	1D6-83363-10	. LENS, RIM	1		B ○
16	←	57M-83358-00	←	. SCREW, SPECIAL	2	*No part number change	

11	28	4YH-83330-00	4YH-83340-01	REAR FLASHER LIGHT ASSY 2	1	*Part number revision (FOR RIGHT)	B
12	29	2AE-83311-00	←	. BULB, FLASHER (12V-21W)	1	*No part number change	
13	30	2AE-83312-00	2AE-83312-10	. LENS, FLASHER	-	*Part number revision	○
14	31	42X-83313-00	1D6-83313-00	. GASKET, FLASHER LENS	1		B ○
15	32	42X-83363-00	1D6-83363-00	. LENS, RIM	1		B ○
16	33	57M-83358-00	←	. SCREW, SPECIAL	2	*No part number change	

*1: Interchangeability

A	Old Parts	→	Old Parts
	New Parts	→	New Parts
B	Old Parts	→	Old Parts
	New Parts	→	New Parts
C	Old Parts	→	Old Parts
	New Parts	→	New Parts
○	These parts are interchangeable with a set		

Parts
Manager
Check

Service
Manager
Check

Parts
Manager
File

YAMAHA MOTOR CO.,LTD
2500 Shingai Iwata Shizuoka 438-8501 Japan
GLOBAL TECHNICAL PUBLICATION DIV.

PARTS NEWS

News No. M/C-04084 3/4

Date: August, 6, 2004

Signature: K. Otsuka

Model	XV535
Subject	PARTS CATALOGUE CORRECTIONS
CATALOGUE NO.	See the "List of Models and CATALOGUE No's below."

2. ILLUSTRATION CORRECTION

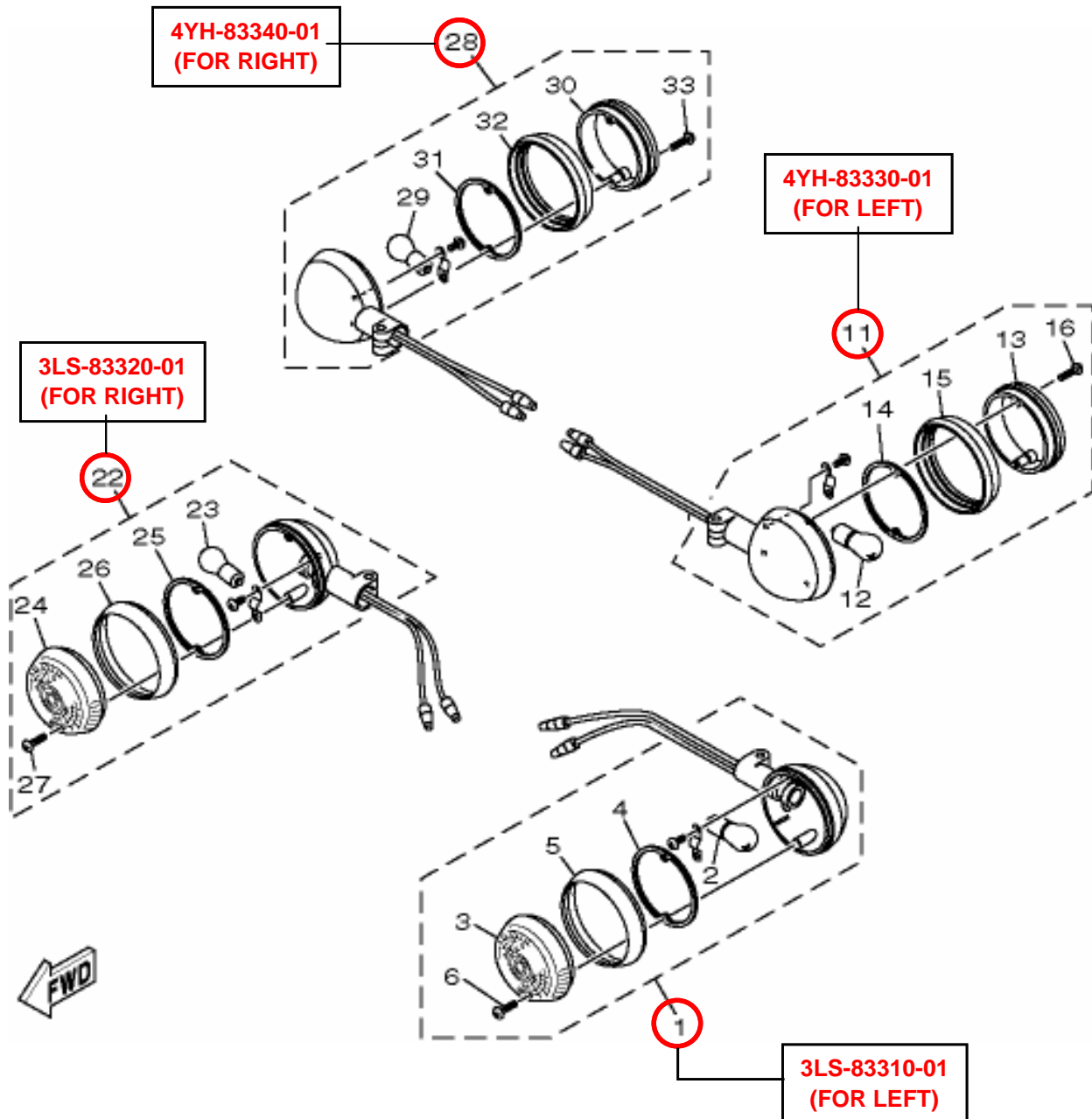

Parts
Manager
Check

Service
Manager
Check

Parts
Manager
File

YAMAHA MOTOR CO., LTD
2500 Shingai Iwata Shizuoka 438-8501, Japan
GLOBAL TECHNICAL PUBLICATION DIV.

PARTS NEWS

News No. M/C-04084 4/4

Date: August, 6, 2004

Signature: K. Otsuka

Model	XV535
Subject	PARTS CATALOGUE CORRECTIONS
CATALOGUE NO.	See the "List of Models and CATALOGUE No's below."

3. LIST of Models and CATALOGUE No's.

The applicable MODELS, MODEL CODES, and CATALOGUE No's are as follows.

MODEL NAME	MODEL CODE	MODEL YEAR	Starting Serial No.	FIG.NO.	CATALOGUE NO.
XV535'99	3BMH	1999	*	36	194YH-300E1
	4YH9		*		
	4YHA		*		
XV535'99	4YH9	1999	*	35	194YH-351F1
	4YHA		*		
XV535'99	4YH9	1999	*	35	194YH-332G1
	4YHA		*		
XV535'99	4YH9	1999	*	35	194YH-352S1
XV535	3BMJ	2000	*	36	104YH-300E1
	4YHB		*		
	4YHC		*		
XV535	4YHB	2000	*	35	104YH-351F1
	4YHC		*		
XV535	4YHB	2000	*	35	104YH-332G1
	4YHC		*		
XV535	4YHB	2000	*	35	104YH-352S1
XV535	4YHD	2001	*	35	114YH-300E1
XV535	4YHD	2001	*	35	114YH-351F1
XV535	4YHD	2001	*	35	114YH-332G1
XV535	4YHE	2001	*	35	114YH-300EA
XV535	4YHE	2001	*	35	114YH-351FA
XV535	4YHE	2001	*	35	114YH-332GA
XV535	4YHE	2001	*	35	114YH-352SA

* These changes are applied from initial production.

Thank you very much for your cooperation.

Parts
Manager
Check

Service
Manager
Check

Parts
Manager
File

YAMAHA MOTOR CO.,LTD
2500 Shingai Iwata Shizuoka 438-8501.Japan
GLOBAL TECHNICAL PUBLICATION DIV.

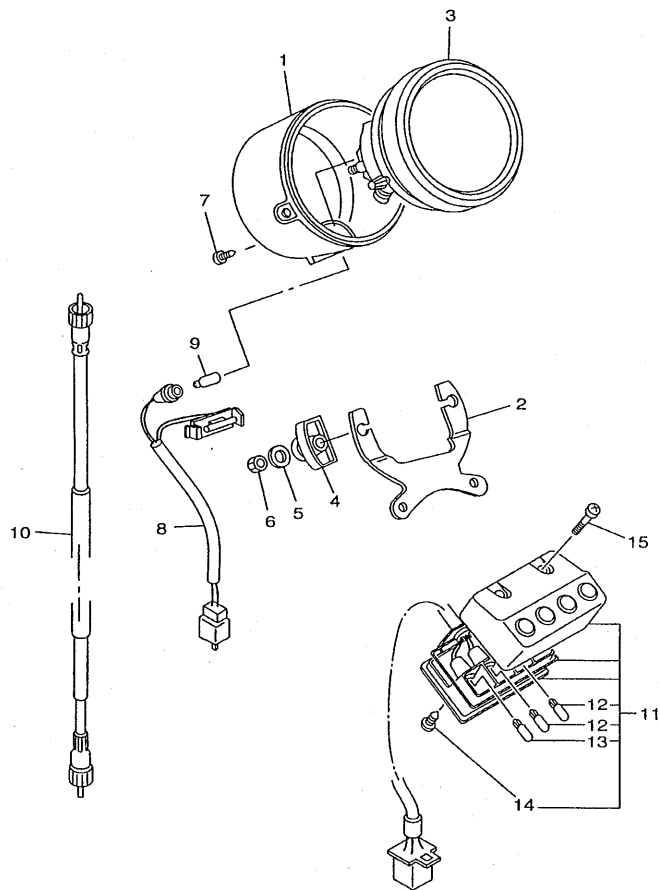

FIG. 36 MEDIDOR

REF. NO.	CODIGO NO.	DESCRIPCION	4YHB				OBSERVACION
1	2JV-8351A-20	MEDIDOR COMPLETA	1				
2	1FK-83507-10	CUBIERTA DE VELOCIMETRO	1				
3	2UJ-83523-00	AMORTIGUADOR	2				
4	92907-05600	ARANDELA	2				
5	95307-05600	TUERCA	2				
6	90164-04009	TORNILLO ROSCA HEMBRA	1				
7	2UJ-83519-00	SOPORTE DE MEDIDOR	1				
8	2UJ-83509-00	ENCASTRE DE CABLE COMPLETO	1				
9	2UJ-83517-00	AMPOLLETA	1				
10	3Y0-83550-01	CABLE DE VELOCIMETRO COMPLETO	1				
11	5AJ-83530-00	LAMPARA PILOTO COMPLETA	1				
12	42X-83517-00	AMPOLLETA (12V-3W)	2				
13	2GV-83517-00	BOMBILLA (12V-1.7W, T6.5)	1				
14	4AS-83616-10	TORNILLO	1				
15	98507-04025	TORNILLO DE CABEZA CON PLANA	2				



4YH9300-9370

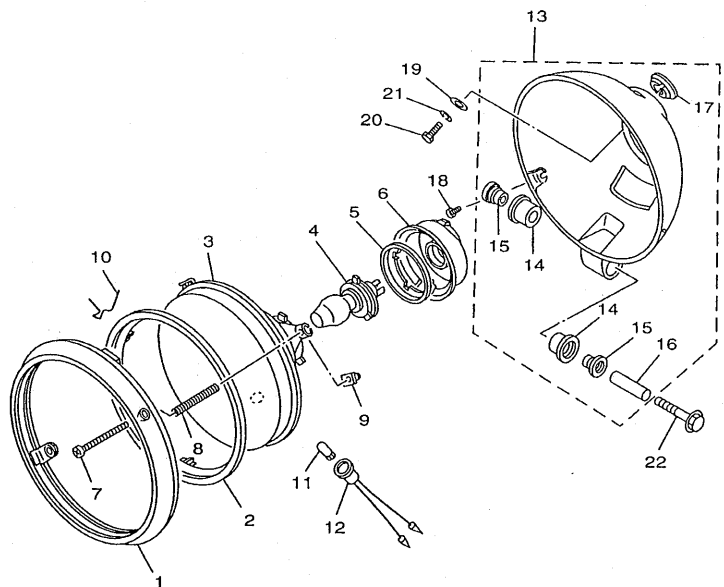

FIG. 37 FARO DELANTERO

REF. NO.	CODIGO NO.	DESCRIPCION	4YHB				OBSERVACION
1	42X-84315-01	ARO DE FARO DELANTERO	1				
2	5Y3-84395-00	ANILLO DE RETEN	1				
3	2AE-84320-G0	LENTE COMPLETO	1				
4	2F9-84314-00	BOMBILLA (12V-60/55W)	1				HALOGEN
5	2F9-84375-00	PLACA FIXATION DE BOMBILLO	1				
6	2F9-84397-01	CUBIERTA DE ENCASTRE	1				
7	341-84331-60	TORNILLO DE AJUSTE DE ARO	2				
8	1A0-84332-60	RESORTE DE TORNILLO	2				
9	198-84334-60	TUERCA DE AJUSTE	2				
10	42X-84124-60	JUEGO DE RESORTES	1				
11	4E2-84347-00	BOMBILLA (12V-4W)	1				
12	34L-84346-00	ENCASTRE DE LUZ PILOTO	1				
13	2UJ-84330-00	CUERPO COMPLETO	1				
14	42X-84345-00	.AMORT DE FARO DELANTERO	2				
15	1FK-84338-00	.COLLAR ACCESORIO DE CUERPO	2				
16	2UJ-84338-00	.COLLAR ACCESORIO DE CUERPO	1				
17	42X-84366-00	.AMORTIGUADOR FARO DELANTERO	1				
18	90157-05084	TORNILLO CABEZA CONICA PLANA	2				
19	90201-060A3	ARANDELA PLANA	1				
20	97007-06016	PERNO	1				
21	92907-06100	ARANDELA	1				
22	95027-06040	PERNO, DE BRIDA	1				



4FTA362-7371

FIG. 38 LUZ DE COLA

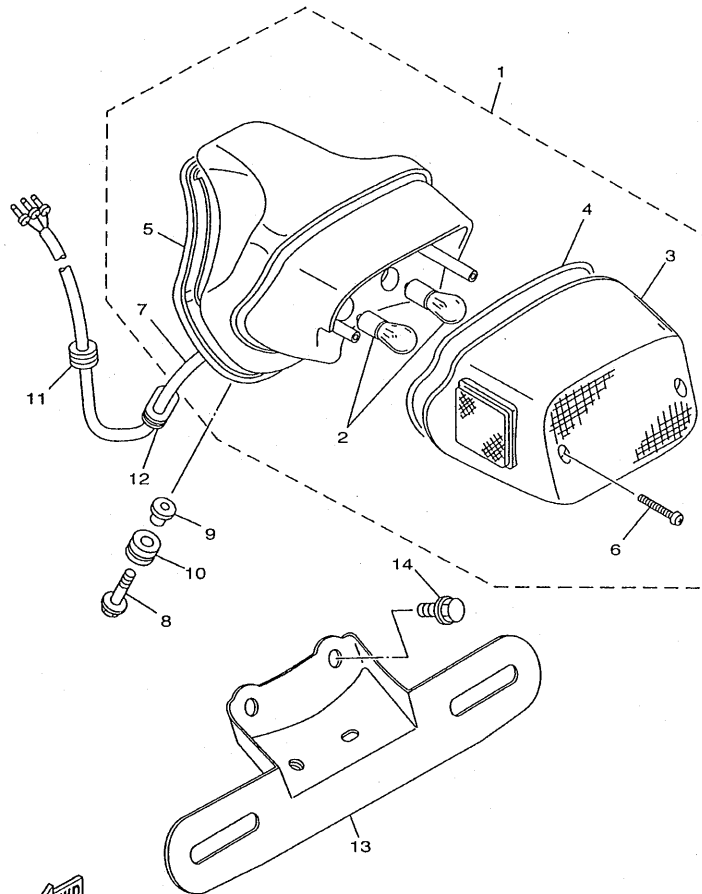



4YH9300-9390

REF. NO.	CODIGO NO.	DESCRIPCION	4YHB				OBSERVACION
1	2YL-84700-E0	FARO TRASERO COMPLET.	1				
2	1A2-84714-41	.AMPOLLETA (12V-21/5W)	2				
3	2AE-84721-00	.LENTE DE FARO TRASERO	1				
4	42X-84723-01	.EMPAQUE LENTE FARO TRASERO	1				
5	1RM-84704-00	.EMPAQUETADURA DE LUZ DE COLA	1				
6	97701-40625	.TORNILLO ROSCA HEMBRA	2				
7	2GV-84717-00	.CABLE DE FARO TRASERO	1				
8	90119-06097	TORNILLO CON ARANDELA	3				
9	90387-06026	CASQUILLO CON VALONA	3				
10	90480-15316	TAPON	3				
11	90480-16501	TAPON	1				
12	90480-01502	TAPON	2				
13	4YH-84751-00	SOPORTE DE LICENCIA	1				
14	95807-06014	TUERCA DE REBORDE	2				

FIG. 39 INTERRUPTOR DE MANIJA. PALANCA

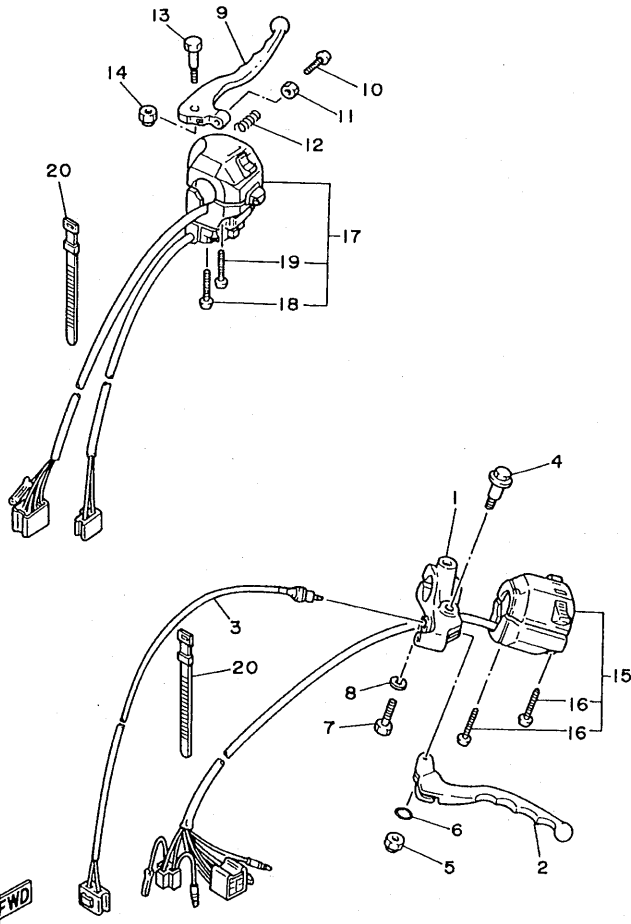
REF. NO.	CODIGO NO.	DESCRIPCION	4YHB				OBSERVACION
1	42X-82911-00	SOPORTE DE LEVA 1	1				
2	2GV-83912-00	PALANCA 1	1				
3	2GV-82917-00	INTERRUPTOR	1				
4	90109-06799	PERNO	1				
5	95607-06100	TUERCA AUTOBLOCANTE	1				
6	93210-11368	ANILLO O	1				
7	97007-06025	PERNO	1				
8	92907-06100	ARANDELA	1				
9	2W1-83922-00	PALANCA 2	1				
10	90149-06131	TORNILLO DE REGLAJE	1				
11	90170-06010	TUERCA	1				
12	90501-10312	RESORTE DE COMPRESION	1				
13	90109-06577	PERNO	1				
14	95607-06100	TUERCA AUTOBLOCANTE	1				
15	4YH-83972-00	INTERRUPTOR DE MANIJA 4	1				
16	98507-05035	.TORNILLO DE CABEZA CON PLANA	2				
17	4YH-83972-10	INTERRUPTOR DE MANIJA 4	1				
18	98507-05040	.TORNILLO DE CABEZA CON PLANA	1				
19	98507-05045	.TORNILLO DE CABEZA CON PLANA	1				
20	437-83936-01	BANDA DE CABLE DE INTERRUPTOR	4				



3BT3351-9430

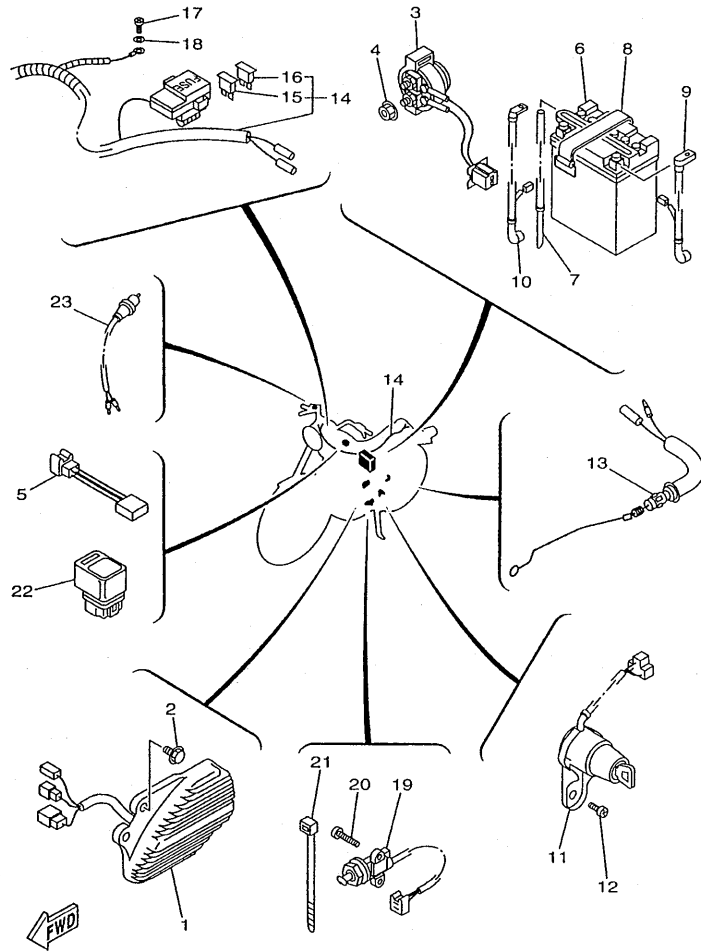

4YHB351-0400

FIG. 40 EQUIPO ELECTRICO 1

REF. NO.	CODIGO NO.	DESCRIPCION	4YHB				OBSERVACION
1	3JB-81960-01	RECTIFICADOR Y REGULADOR	1				
2	95807-06012	TUERCA DE REBORDE	2				
3	3AY-81940-00	CONJUNTO ARRANCADOR RELEVO	1				
4	95707-06500	TUERCA DE BRIDA	2				
5	4H7-81980-M0	RECTIFICADOR 2	1				
6	1VJ-82110-61	BATERIA COMPLETA (GM12AZ-3A-2)	1				
7	90445-08248	TUBO	1				
8	120-82131-00	TIRANTE DE BATERIA	1				
9	2GV-82115-00	CABLE CONDUCTOR POSITIVO	1				
10	2GV-82116-00	CABLE CONDUCTOR NEGATIVO	1				
11	2NT-82510-01	CONJUNTO DE LLAVE IGNICION	1				
12	92017-08016	PERNO	1				
13	2GV-82530-10	INTERRUPTOR DE PARADA COMPLETO	1				
14	4KU-82590-00	CONJUNTO DE CABLES	1				
15	36Y-82151-00	.FUSIBLE (15A-BL)	4				
16	1AE-82151-00	.FUSIBLE (30A-BL)	2				
17	98507-06010	TORNILLO DE CABEZA CON PLANA	1				
18	92907-06600	ARANDELA	1				
19	3LD-82566-70	INTERRUPTOR	1				
20	90157-05079	TORNILLO CABEZA CONICA PLANA	2				
21	12R-82591-00	BANDA	1				
22	25G-81950-01	RELE COMPLETO	1				
23	1A0-83980-30	INTERRUP.PARADA DELANTERO	1				

FIG. 41 EQUIPO ELECTRICO 2

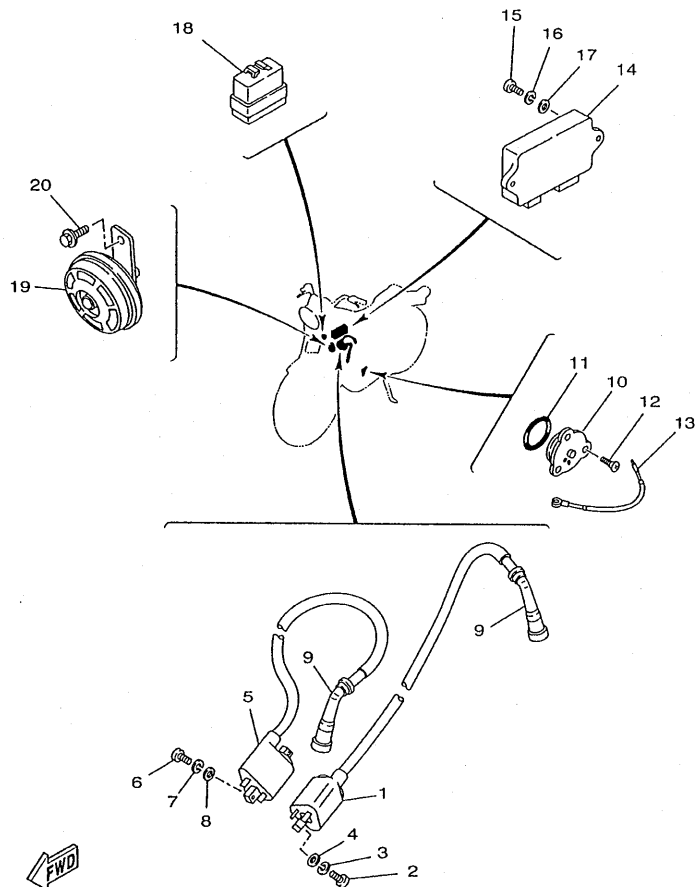

REF. NO.	CODIGO NO.	DESCRIPCION	4YHB				OBSERVACION
1	2GV-82310-30	BOBINA DE ENCENDIDO COMPLETA	1				
2	98507-05016	TORNILLO DE CABEZA CON PLANA	2				
3	92907-05100	ARANDELA	2				
4	92907-05600	ARANDELA	2				
5	2GV-82320-30	BOBINA DE ENCENDIDO COMPLETA	1				
6	98507-05016	TORNILLO DE CABEZA CON PLANA	2				
7	92907-05100	ARANDELA	2				
8	92907-05600	ARANDELA	2				
9	2GV-82370-00	TAPON DE BUJIA COMPLT	2				
10	1L9-82540-00	INTERRUPTOR NEUTRAL COMPL	1				
11	93210-29196	ANILLO O	1				
12	90149-05321	TORNILLO DE REGLAJE	3				
13	22U-82509-00	CABLE SUBCONDUCTOR	1				
14	3BT-82305-00	UNIDAD DE ENCENDIDO COMPLETA	1				
15	98507-06020	TORNILLO DE CABEZA CON PLANA	2				
16	92907-06100	ARANDELA	2				
17	92907-06600	ARANDELA	2				
18	41R-83350-71	RELE DE DESTELLADOR COMPL.	1				
19	35J-83371-32	BOCINA	1				
20	95807-06010	TUERCA DE REBORDE	1				

FWD
4BU6700-5422

INDICE NUMERICO

CODIGO NO.	REF. NO.	CODIGO NO.	REF. NO.	CODIGO NO.	REF. NO.	CODIGO NO.	REF. NO.	CODIGO NO.	REF. NO.	CODIGO NO.	REF. NO.
4H7-W0041-00	E - 6	2GV-11610-40	B - 5	1FK-14147-00	B - 13	341-14954-00	B - 13	22U-17402-00	C - 9	3WF-2153E-40	D - 7
4BP-W0045-00	E - 2	2GV-11631-00-CO	B - 5	214-14147-00	B - 13	22U-14968-00	B - 12	4VR-17411-00	C - 9	4KU-21570-B0	C - 15
3JB-W0047-00	E - 2	22U-11633-01	B - 5	22U-14147-00	B - 12	22U-14968-00	B - 12	22U-17524-00	C - 10	4KU-21570-CO	C - 15
51L-W0048-00	E - 2	2GV-11636-00	B - 5	22V-14147-00	B - 13	1FK-14985-00	B - 12	22U-17527-01	C - 10	4KU-21570-80	C - 15
3JB-W0057-00	E - 2	2GV-11638-00	B - 5	137-14153-00	B - 12	31H-14987-00	B - 13	3H5-17529-00	C - 10	2NT-21597-01	C - 15
4H7-W1752-10	C - 10	22U-11650-00	B - 5	1FK-14190-15	B - 12	22F-14991-00	B - 13	3JB-17531-00	C - 10	3JB-21598-00	C - 15
2GV-W2341-00-38	D - 7	22U-11654-00	B - 5	2L1-14191-00	B - 13	341-14991-00	B - 13	3JB-17531-10	C - 10	2GV-2160E-00	C - 15
3DR-W2536-00	E - 3	22U-11656-00	B - 5	127-14198-00	B - 13	1HX-14994-00	B - 13	3JB-17531-20	C - 10	2GV-21629-00-JW	C - 15
22U-Y1754-00	C - 10	22U-11656-10	B - 5	3JB-14199-00	B - 12	2GV-15100-03	C - 2	1J7-17537-Y0-30	D - 5	2GV-21629-00-P6	C - 15
2GV-Y2150-E1-JW	C - 15	22U-11656-20	B - 5	3G2-1423A-72	B - 13	2GV-15316-00	C - 4	1J7-17537-Y0-40	D - 5	2GV-21629-00-P7	C - 15
2GV-Y2150-H1-PC	C - 15	22U-11656-30	B - 5	3G2-14231-14	B - 12	2H7-15361-00	C - 4	1J7-17537-Y0-50	D - 5	2GV-2163A-00	C - 15
2GV-Y2150-K1-PD	C - 15	22U-12111-00	B - 6	3G2-14231-34	B - 12	3F9-15362-00	C - 4	4H7-17537-00-20	C - 10	2GV-2163E-00	C - 15
4YH-Y2161-1C-JW	C - 15	22U-12113-00	B - 6	3JB-14409-00	B - 10	11H-15383-01	C - 2	4H7-17537-00-30	C - 10	4YH-21641-00	D - 2
4YH-Y2161-1E-P2	C - 15	22U-12114-00	B - 6	3JB-14412-00	B - 10	3JB-15411-01	C - 4	4H7-17537-00-40	C - 10	4KU-2165A-B0	C - 15
4YH-Y2161-1F-P1	C - 15	3Y1-12116-00	B - 6	3JB-14414-00	B - 11	3JB-15415-00	C - 4	22U-17553-01	C - 10	4KU-2165A-C0	C - 15
3BR-Y2428-S0-2X	D - 11	3Y1-12117-01	B - 6	3JB-14417-00	B - 10	3JB-15421-00	C - 4	22U-17556-00	C - 10	4KU-2165A-80	C - 15
3BR-Y2428-V0-5X	D - 11	1J7-12118-00	B - 6	3JB-1442G-00	B - 10	22U-15441-01	C - 3	2GV-17590-00	D - 6	2GV-2171E-00	C - 13
3BR-Y2428-X0-6X	D - 11	1J7-12119-01	B - 6	3JB-14422-00	B - 10	4VR-15451-00	C - 4	2GV-18110-00	C - 12	2GV-21711-00-JW	D - 3
2NT-1110M-01	B - 3	22U-12121-01	B - 6	3JB-14425-00	B - 11	4VR-15461-00	C - 4	2GV-18112-00	C - 12	2GV-21711-00-P6	D - 3
2GV-11102-02	B - 2	22U-12151-00	B - 6	3JB-14426-00	B - 10	3BT-15484-00	C - 4	132-18113-01	C - 12	2GV-21711-00-P7	D - 3
22U-1111F-01	B - 3	22U-12156-01	B - 6	3JB-14437-01	B - 10	22U-15512-00	C - 6	2GV-18115-00	C - 12	3JB-2172E-00	D - 3
2GV-1111H-00	B - 2	22U-12159-00	B - 6	2NT-14451-00	B - 10	4TR-15517-00	C - 6	22U-18120-02	C - 12	3JB-2172F-00	D - 3
2GV-11127-00	B - 2	22U-12171-01	B - 7	2GV-14452-00	B - 10	5H0-15521-00	C - 6	4G0-18127-00	C - 12	2GV-21721-00-JW	D - 3
4H7-11133-10	B - 2	22U-12176-01	B - 7	3JB-14452-00	B - 10	4TR-15590-00	C - 6	4TR-18140-00	C - 12	2GV-21721-00-P6	D - 3
2GV-11142-00	B - 2	22U-12181-01	B - 7	3JB-14455-00	B - 10	4KU-16111-00	C - 7	2H9-18154-00	C - 12	2GV-21721-00-P7	D - 3
22U-11145-00	B - 7	11H-12210-02	B - 7	22U-14469-00	B - 10	22U-16150-01	C - 7	4H7-18185-00	C - 11	3JB-2176E-00	D - 3
2GV-11152-00	B - 2	3BT-12213-00	B - 7	31A-14477-00	D - 3	22U-16154-00	C - 7	4TR-18511-00	C - 11	4KU-21781-00	D - 3
15A-11162-00	B - 4	22U-12231-00	B - 7	2GV-14484-00	B - 15	22U-16321-00	C - 7	4TR-18512-00	C - 11	2GV-22110-00-35	D - 4
22U-11165-00	B - 2	22U-12241-00	B - 7	3JB-14536-00	B - 12	4X7-16324-00	C - 7	4TR-18513-00	C - 11	4X7-22124-00	D - 4
2GV-11166-00	B - 2	22U-13300-00	B - 8	22U-14565-00	B - 12	4X7-16325-00	C - 7	3YF-18531-00	C - 11	4X7-22129-00	D - 4
2GV-11181-00	B - 2	22U-13324-00	B - 8	2GV-14603-00	B - 15	22U-16351-00	C - 7	4TR-18535-00	C - 11	4X7-22141-00	D - 4
2GV-11185-00	B - 2	4VR-13325-00	B - 8	4BE-14613-00	B - 15	4PT-16356-01	C - 7	4TR-18540-02	C - 11	22U-22189-00	D - 4
2NT-11186-01	B - 3	22U-13410-00	B - 8	4BR-14613-00	B - 15	22U-16357-00	C - 8	4UN-18542-00	C - 11	2YL-22210-01	D - 4
22U-11186-00	B - 2	22U-13415-00	B - 8	2GV-14625-00	B - 15	1W1-16358-01	C - 7	4UN-18566-00	C - 11	2GV-22216-00	D - 4
2NT-11187-01	B - 3	2GV-13417-00	B - 8	2GV-14663-00	B - 15	22U-16371-02	C - 7	3JB-21105-00-33	C - 13	2YL-22220-01	D - 4
22U-11187-00	B - 2	4X7-13440-01	B - 9	4KU-14703-00	B - 15	22U-16380-00	C - 7	4FT-21110-10-33	C - 13	2GV-22226-00	D - 4
3BT-11195-00	B - 3	3JB-13447-00	B - 9	22U-1490H-00	B - 12	4X7-16383-01	C - 7	2GV-21171-00	D - 3	2GV-22253-00	D - 4
3BT-11195-00	B - 3	16G-13569-00	B - 10	3BM-1490J-00	B - 12	4X7-16384-00	C - 7	4R8-21308-00	D - 2	5M0-22253-00	D - 4
214-11198-01	D - 6	2GV-13586-01	B - 10	3BM-1490J-10	B - 12	4X7-16385-00	C - 7	22U-21315-00	C - 13	4KU-23102-01	D - 9
		2GV-13596-00	B - 10	3EN-1490K-00	B - 13	2KV-17121-00	C - 9	22U-21316-00	C - 13	4KU-23103-01	D - 9
		2GV-13907-00	D - 13	3BM-1490L-00	B - 13	4KU-17131-00	C - 9	2GV-21317-00	C - 13	2GV-23110-01	D - 9
2GV-11310-00	B - 4	11H-1410A-00	B - 12	4KU-14900-12	B - 12	22U-17141-00	C - 9	2GV-21359-00	C - 14	1HX-23111-00	D - 10
2GV-11320-00	B - 4	22U-14103-00	B - 14	4KU-14901-12	B - 12	11H-17151-01	C - 9	2GV-2136L-00	B - 15		
3BT-11351-01	B - 4	12R-14105-00	B - 13	4KU-14902-12	B - 12	22U-17211-00	C - 9	2GV-2139R-00	C - 14	2GV-23125-00	D - 9
22U-11411-00	B - 5	41R-14118-01	B - 13	1FK-14933-00	B - 12	4KU-17221-00	C - 9	3JB-2139R-00	C - 14	3JB-23126-11	D - 9
22U-11416-80	C - 2	4FT-1414G-00	B - 13	41R-14940-00	B - 12	4KU-17231-00	C - 9	1AA-2143A-00	C - 14	3JB-23136-11	D - 9
22U-11416-90	C - 2	2JU-14141-90	B - 12	22U-14952-00	B - 13	22U-17241-00	C - 9	4KU-21458-00	C - 13	2GV-23141-00	D - 10
2GV-11610-00	B - 5	4G0-14142-35	B - 12	26H-14952-00	B - 13	11H-17251-00	C - 9	4X7-21465-00	C - 13		
2GV-11610-20	B - 5										

INDICE NUMERICO

CODIGO NO.	REF. NO.	CODIGO NO.	REF. NO.	CODIGO NO.	REF. NO.	CODIGO NO.	REF. NO.	CODIGO NO.	REF. NO.	CODIGO NO.	REF. NO.
2GV-23144-00	D - 10	3JB-24314-00	D - 13	4H7-25850-02	E - 6	2H7-46122-00	D - 5	4YH-83330-00	E - 11	4YH-84751-00	E - 14
	D - 9	3JB-24316-00	D - 11	4H7-25852-00	E - 6	22U-46123-00	D - 6	41R-83350-71	F - 3	3Y6-85130-02	D - 2
2AJ-23145-00	D - 10	3JB-24317-00	D - 11	4L0-25854-00	E - 6	4H7-46125-00	D - 5	57M-83358-00	E - 11	90101-06288	E - 7
	D - 9	2GV-24491-00	D - 12	4L0-25867-00	E - 6	22U-46136-00	D - 5	42X-83363-00	E - 11	90101-06576	B - 15
1GU-23151-00	D - 9	3JB-24500-03	D - 12	4KU-25872-00	E - 6	22U-46137-00	D - 6	18G-83365-00	E - 11	90101-06764	E - 3
1HX-23154-00	D - 10	4X8-24512-00	D - 12	3JB-25886-00	D - 10	22U-46152-00	D - 5	35J-83371-32	F - 3	90101-10303	B - 7
	D - 9	3AJ-24523-00	D - 12	3YX-25919-00	E - 2	22U-46153-00	D - 5	1FK-83507-10	E - 12	90105-08069	C - 13
1HX-23156-00	D - 10	3AJ-24534-00	D - 12	3YX-25926-00	E - 2	2GV-46172-00	D - 6	2UJ-83509-00	E - 12	90105-08066	C - 13
	D - 9	1FK-24560-00	D - 12	3YX-25929-00	E - 2	4X7-46180-00	D - 6	2JV-8351A-20	E - 12	90105-10152	C - 6
1GU-23157-00	D - 9	1FK-24566-00	D - 12	3YX-25937-00	E - 2	2GV-81410-20	E - 10	2GV-83517-00	E - 12	90105-10183	C - 13
2NT-23164-00	D - 7	4X7-24602-04	D - 11	5R2-25937-00	E - 2	4TR-81450-00	C - 6	2UJ-83517-00	E - 12	90105-10186	C - 13
2GV-2317E-00	D - 7	4X7-24612-00	D - 11	2GV-26111-11	E - 5	3BT-81670-00	E - 10	42X-83517-00	E - 12	90105-10188	E - 9
2GV-2317F-00	D - 7	47X-24705-00	D - 14	3JB-26240-00	E - 5	1HX-81815-00	C - 6	2UJ-83519-00	E - 12	90105-10200	E - 3
2GV-2317M-00	D - 7	3JB-24710-10	D - 14	3JB-26241-00	E - 5	4XV-8182A-00	C - 6	2UJ-83523-00	E - 12	90105-10285	D - 6
2GV-23171-01	D - 9	3JB-24711-10	D - 14	3JB-26273-00	E - 5	3HE-81826-00	C - 6	5AJ-83530-00	E - 12	90105-10285	D - 6
1GU-23173-00	D - 9	3JB-24718-00	D - 14	3JB-2628J-00	E - 5	3KS-81840-00	C - 6	3Y0-83550-01	E - 12	90105-10312	E - 8
2GV-23174-01	D - 7	18A-24724-00	D - 14	4H7-26290-A1	E - 5	11H-81844-00	C - 6	4AS-83616-10	E - 12	90105-10638	E - 2
3JC-23317-00	D - 7	3JB-24728-00	D - 14	4H7-26290-E1	E - 5	1FK-81847-00	C - 6	2GV-83912-00	E - 15	90105-12353	D - 10
3BR-23340-00	D - 10	3JB-24734-10	D - 14	3JC-26311-00	E - 5	3JB-81890-00	C - 6	2W1-83922-00	E - 15	90105-14102	D - 7
156-23411-00	D - 10	3JB-24750-10	D - 14	3JC-26312-00	E - 5	3AY-81940-00	F - 2	3TB-83936-00	D - 7	90106-10052	D - 4
183-23411-00	D - 7	3JB-24751-10	D - 14	3JB-26335-20	E - 5	25G-81950-01	F - 2	437-83936-01	E - 15	90109-06577	E - 15
156-23412-00	D - 7	3JB-24776-00	D - 14	2GV-26351-00	E - 7	3JB-81960-01	F - 2	437-83936-11	D - 12	90109-06799	E - 15
183-23412-00	D - 7	3JB-2478F-00	D - 14	5H0-26393-00	E - 5	4H7-81980-M0	F - 2	4YH-83972-00	E - 15	90109-081F0	E - 2
136-23415-00	D - 7	51Y-24796-00	D - 14	2GV-27211-00-93	E - 7	1VJ-82110-61	F - 2	4YH-83972-10	E - 15	90109-08368	E - 4
4H7-23441-00-38	D - 7	3JB-25104-01	D - 15	4KU-27311-12	E - 9	2GV-82115-00	F - 2	4YH-83972-10	E - 15	90109-08406	E - 4
42X-23442-00-38	D - 7	4KU-25111-00	D - 15	5H0-27315-00	E - 9	2GV-82116-00	F - 2	1A0-83980-30	F - 2	90109-08406	E - 4
164-23462-00	D - 10	341-25149-00	D - 15	1RM-27410-00-93	E - 7	120-82131-00	F - 2	42X-84124-60	E - 13	90109-08718	C - 13
134-23484-10	D - 8	2GV-25181-00	D - 15	1NH-27413-00	E - 7	1AE-82151-00	F - 2	2F9-84314-00	E - 13	90109-08781	B - 3
3JB-24110-01-33	D - 11	4TX-25190-10	D - 15	4X7-27414-00	E - 8	36Y-82151-00	F - 2	42X-84315-01	E - 13	90109-08782	B - 3
3JB-24135-00	D - 11	2GV-25304-01	E - 3	1RM-27420-00-93	E - 7	3BT-82305-00	F - 3	2AE-84320-G0	E - 13	90109-100G0	E - 8
4MC-24161-00	D - 13	2GV-25311-00-35	E - 3	2NT-27430-01	E - 8	2GV-82310-30	F - 3	2UJ-84330-00	E - 13	90110-06198	B - 3
4MC-24162-00	D - 13	2GV-25315-00	E - 3	1NH-27433-00	E - 8	2GV-82320-30	F - 3	341-84331-60	E - 13	90110-08212	C - 6
2GV-24181-00	D - 11	2GV-25317-00	E - 3	2NT-27437-00	E - 8	2GV-82370-00	F - 3	1A0-84332-60	E - 13	90116-08404	C - 2
1FK-24182-00	D - 11	1J7-25319-01	D - 6	2NT-27440-01	E - 8	22U-82509-00	F - 3	198-84334-60	E - 13	90116-10249	D - 5
	D - 12	2GV-25319-00	E - 3	2GV-27471-02	E - 8	2NT-82510-01	F - 2	1FK-84338-00	E - 13	90116-10405	C - 2
3JB-24182-00	D - 11	2NT-25321-00	E - 3	2GV-27472-02	E - 8	2GV-82530-10	F - 2	2UJ-84338-00	E - 13	90116-10406	C - 2
1FK-24183-00	D - 11	4H7-2533A-02	E - 3	2GV-27491-00	E - 8	119-82540-00	F - 3	42X-84345-00	E - 13	90116-10428	D - 5
	D - 12	4H7-25351-00	E - 3	2GV-28100-00	D - 14	3LD-82566-70	F - 2	34L-84346-00	E - 13	90116-12495	C - 13
42X-24183-00	D - 11	214-25355-00	E - 3	3JB-28185-00	D - 3	4KU-82590-00	F - 2	4E2-84347-00	E - 13	90119-06097	E - 14
2GV-24184-00	D - 12	2GV-25366-00	E - 3	2NT-46101-00	D - 5	12R-82591-00	F - 2	42X-84366-00	E - 13	90119-06097	E - 14
1FK-24186-00	D - 11	42X-25371-02	E - 4	22U-46117-00-25	D - 5	42X-82911-00	E - 15	2F9-84375-00	E - 13	90119-06123	C - 15
	D - 12	22U-25377-00	E - 4	22U-46117-00-30	D - 5	2GV-82917-00	E - 15	5Y3-84395-00	E - 13	D - 12	
2GV-24191-00	D - 12	2GV-25381-00	E - 3	22U-46117-00-40	D - 5	3LS-83310-00	E - 11	2YL-84700-E0	E - 14	D - 3	
4KU-24240-71	D - 11	5V4-25398-00	D - 15	22U-46118-00-12	D - 5	2AE-83311-00	E - 11	1RM-84704-00	E - 14	D - 3	
4KU-24240-80	D - 11		E - 3	22U-46118-00-14	D - 5	2AE-83312-00	E - 11	1A2-84714-41	E - 14	F - 3	
4KU-24240-90	D - 11	3JB-2580U-11	E - 2	22U-46118-00-16	D - 5	42X-83312-00	E - 11	2GV-84717-00	E - 14	90149-06008	D - 13
2GV-24311-00	D - 12	3JB-2582U-01	E - 2	22U-46118-00-18	D - 5	42X-83313-00	E - 11	2AE-84721-00	E - 14	90149-06131	E - 15
2GV-24312-00	D - 12	341-25846-00	D - 15	22U-46118-00-20	D - 6	1AA-83318-00	E - 11	42X-84723-01	E - 14	90149-06154	D - 2
										90149-08067	C - 8

INDICE NUMERICO

CODIGO NO.	REF. NO.	CODIGO NO.	REF. NO.	CODIGO NO.	REF. NO.	CODIGO NO.	REF. NO.	CODIGO NO.	REF. NO.	CODIGO NO.	REF. NO.
90149-08152	C- 3	90201-10131	B- 2	90387-06518	B- 3	90480-19471	B- 3	91317-06095	C- 2	92907-06600	B- 7
90149-10238	C- 13			90387-07391	D- 3	90480-22362	D- 3	91317-08025	D- 10		D- 3
90149-10239	C- 13	90201-10140	C- 13	90387-074T1	B- 3	90501-06022	C- 11		D- 9		E- 6
90151-08022	C- 3	90201-10141	D- 7	90387-087K5	E- 7	90501-100F8	D- 13	91317-08080	C- 2		F- 2
90157-05050	B- 13	90201-104A7	C- 13	90387-100E2	C- 13	90501-101J4	D- 11	91380-06025	C- 5		F- 3
90157-05079	F- 2	90201-105R9	D- 4	90387-1003G	E- 9	90501-10245	E- 7	91401-20012	E- 7	92907-08100	B- 15
90157-05084	E- 13	90201-10591	B- 7	90387-107A7	E- 8	90501-10312	E- 15	91401-20015	E- 4	92907-08200	B- 15
90159-06016	C- 7	90201-107E9	C- 6	90387-156G8	D- 6	90501-12743	E- 8		E- 8	92907-10200	E- 9
90159-06059	C- 15	90201-12575	C- 12	90387-157R0	E- 4	90501-15722	D- 6	91401-25015	E- 7	92990-06600	B- 15
90163-04003	B- 15	90201-12588	C- 12	90387-16547	C- 2	90501-23738	C- 7	91401-30030	E- 4		C- 6
90164-04009	E- 12	90201-12688	C- 12	90387-177R1	D- 15	90501-60716	C- 10	91701-06022	E- 7	93101-14089	C- 4
90170-06010	E- 15	90201-14577	E- 3	90387-226G7	B- 2	90506-08227	C- 12	91701-06032	E- 8	93101-30084	D- 5
90170-06128	B- 6	90201-146R0	E- 4	90387-256G9	D- 5	90506-20380	E- 7	91815-16017	C- 2	93101-35097	C- 10
90170-06228	C- 12	90201-14633	C- 10	90401-10159	E- 6	90506-23490	E- 9		C- 5	93101-38098	D- 5
90170-16256	C- 7	90201-152L1	E- 7	90401-16166	B- 3	90506-29507	E- 9	92016-06012	E- 8	93102-12106	C- 12
90170-20310	C- 7	90201-18262	C- 8	90430-08119	C- 8	90507-20002	E- 3	92017-06010	D- 2	93102-18278	C- 7
90171-14044	E- 4	90201-244A8	D- 4	90430-17168	B- 3	90508-16577	C- 8	92017-08016	F- 2	93102-28022	D- 15
90173-06015	B- 11	90201-25290	C- 6	90430-24184	B- 2	90508-18696	E- 7	92502-08014	B- 13	93102-65277	D- 6
90176-10073	D- 4	90202-05193	C- 13	90445-08248	F- 2	90508-290B5	C- 12	92701-06010	B- 13	93105-45017	D- 15
90179-06411	E- 7			90445-111F3	B- 10	90508-32536	C- 12	92901-04100	B- 12	93210-03119	B- 13
90179-08148	E- 5	90208-04029	D- 8	90445-11152	B- 11	90560-08326	D- 2		B- 13	93210-09525	C- 7
90179-08327	B- 5	90209-22191	C- 9	90445-11290	B- 11	90560-17126	D- 15	92902-04100	B- 12	93210-10096	B- 8
90179-08410	B- 15	90209-27192	C- 9	90445-16641	E- 9	91314-06018	C- 4	92903-06600	B- 15	93210-11368	E- 15
90179-10247	C- 13	90214-16026	C- 7	90450-22017	D- 11	91314-06025	B- 2	92903-08100	E- 4	93210-14369	C- 4
90179-10279	B- 2	90215-08229	B- 3	90450-25037	D- 11			92903-08200	D- 2	93210-15151	B- 8
	C- 13	90215-16157	C- 7	90460-12256	B- 10			92903-08600	E- 4	93210-15566	C- 5
90179-10395	B- 2	90215-16181	D- 4	90460-52210	B- 10			92903-10100	D- 4	93210-18322	C- 2
90179-12248	C- 13	90215-18178	C- 12	90460-58124	B- 10	91314-06030	C- 4		D- 6	93210-24709	D- 10
90179-18396	C- 10	90215-22210	C- 7	90462-06119	C- 5	91314-06040	C- 4	92904-06600	B- 3		D- 9
90179-25033	D- 7	90240-08084	E- 7	90462-10115	C- 5	91314-08045	C- 2	92904-08100	D- 4	93210-27370	C- 4
90183-04027	B- 15	90249-12008	E- 7	90462-10118	C- 5	91314-06055	C- 2	92907-03200	D- 14	93210-29196	F- 3
90185-08097	B- 15	90269-04003	D- 8	90465-13152	E- 8			92907-05100	E- 3	93210-32172	C- 4
90185-14070	C- 10	90280-05048	B- 5	90467-10008	D- 13	91314-06060	B- 9		F- 3	93210-36769	B- 10
90201-060A3	E- 13	90280-07036	C- 7	90467-10039	B- 10	91314-06095	B- 9	92907-05600	E- 12	93210-60426	D- 5
90201-06071	B- 3	90338-07043	C- 14	90467-10041	B- 13	91314-08030	B- 2		E- 3	93210-62446	B- 3
90201-06380	B- 10	90338-08163	D- 7	90467-10135	D- 12				F- 3	93210-64297	B- 9
	D- 3	90338-09161	E- 8	90467-12053	D- 12	91314-08035	D- 9	92907-06100	D- 12	93210-71360	C- 10
90201-065G8	D- 12	90340-14009	D- 6		D- 13	91314-08060	C- 2		D- 14		D- 2
90201-066M2	D- 11	90340-14132	B- 8	90467-14015	B- 2	91314-08100	C- 2		D- 3	93210-74316	C- 4
90201-06765	D- 14	90340-14139	C- 4	90480-01502	E- 14	91317-05010	D- 11		E- 10	93210-81411	B- 4
90201-081E6	D- 10	90340-32140	C- 4	90480-10334	C- 14	91317-06016	D- 7		E- 13	93210-89568	B- 2
	D- 9	90380-28110	B- 7	90480-12320	D- 3	91317-06020	B- 10		E- 15	93211-00612	B- 2
90201-08326	C- 13	90387-06026	E- 14	90480-13163	D- 12	91317-06025	B- 15		F- 3	93211-39569	D- 6
90201-08366	B- 2	90387-062G5	D- 11	90480-14102	D- 13			92907-06200	C- 7	93306-00401	C- 10
90201-08569	D- 11			90480-14229	D- 3	91317-06030	B- 11		E- 7		C- 9
90201-08753	D- 4	90387-062L2	D- 12	90480-15316	E- 14			92907-06600	B- 10	93306-00428	C- 9
90201-100A1	E- 8	90387-062T3	B- 10	90480-16501	E- 14	91317-06045	C- 2		B- 11	93306-20711	C- 10
90201-10118	E- 6	90387-063E6	D- 13	90480-18411	B- 3	91317-06085	B- 4		B- 3	93306-30202	E- 3

INDICE NUMERICO

CODIGO NO.	REF. NO.	CODIGO NO.	REF. NO.	CODIGO NO.	REF. NO.	CODIGO NO.	REF. NO.	CODIGO NO.	REF. NO.	CODIGO NO.	REF. NO.
93306-30209	E- 3	95304-08700	E- 4	97027-08030	B- 15						
93306-30319	D- 15		E- 5	97070-06025	C- 6						
93306-30525	C- 9	95307-05600	D- 2	97701-40625	E- 14						
93306-30539	D- 5		E- 12	97704-40012	B- 15						
93306-90602	C- 11	95307-06600	C- 7	97707-60514	C- 14						
93311-21044	D- 6	95307-06700	E- 7	97880-05014	B- 12						
93311-43729	D- 5	95307-12600	E- 11	98501-04010	B- 13						
93315-21813	C- 7	95307-12800	C- 13	98501-04012	B- 12						
93316-01301	D- 5	95314-10600	D- 6	98501-05010	B- 13						
93317-41510	D- 5	95317-08700	B- 15	98501-05012	B- 13						
93320-32403	D- 4	95607-06100	E- 15	98502-04018	B- 12						
93410-22039	D- 6		E- 7	98504-06020	B- 15						
93440-12052	B- 2	95607-10100	D- 7	98507-03008	D- 12						
93440-19112	D- 6	95617-08630	B- 2	98507-04025	E- 12						
93440-20088	D- 6	95617-10100	E- 9	98507-05008	E- 5						
93440-25084	C- 9	95617-10680	C- 2	98507-05012	E- 3						
93440-30077	C- 9	95704-06500	E- 11	98507-05016	D- 12						
93450-19052	B- 5	95704-10500	E- 8		F- 3						
93450-32116	D- 10	95707-06500	D- 14	98507-05035	E- 15						
	D- 9		F- 2	98507-05040	E- 15						
93501-04011	D- 7	95707-08500	B- 2	98507-05045	E- 15						
	E- 8	95804-10016	E- 9	98507-06010	C- 5						
93515-32029	C- 8	95807-06010	C- 15		F- 2						
93604-16092	C- 11		D- 10	98507-06012	B- 14						
93604-20156	C- 11		F- 3	98507-06020	E- 10						
93605-10108	B- 7	95807-06012	C- 14		F- 3						
94114-156U1	E- 3		D- 14	98507-06025	E- 10						
94114-156U2	E- 3		F- 2	98507-06035	B- 10						
94130-197N0	D- 15	95807-06014	E- 14		D- 3						
94130-197N1	D- 15	95807-06016	D- 12	98507-06050	D- 3						
94214-15223	E- 3	95807-06020	D- 3	98517-06160	B- 10						
94227-19177	D- 15	95807-06025	D- 13	98706-04012	E- 6						
94325-19115	D- 15	95807-08012	C- 15	98707-05035	C- 11						
94330-15134	E- 3		D- 4	98904-08014	D- 2						
94418-19543	D- 15	95807-08016	B- 15	99001-10600	C- 12						
94430-15544	E- 3	95827-08030	C- 10	99009-11400	B- 8						
94591-41118	B- 7	97004-08035	D- 4	99009-12400	C- 12						
94701-00228	B- 3	97007-06014	D- 14	99009-15400	E- 7						
94701-00234	B- 3	97007-06016	E- 13	99009-25500	C- 4						
95024-06008	D- 7	97007-06025	D- 3	99246-00080	C- 15						
95024-06025	D- 11		E- 15	99247-00080	C- 15						
95024-06030	E- 11		E- 6	99530-10014	C- 4						
95024-08040	D- 7	97007-08016	D- 11	99530-10120	C- 4						
95027-06016	C- 13	97024-06016	B- 3	99530-14016	C- 2						
95027-06020	D- 7	97024-06020	C- 12	99530-17016	B- 2						
95027-06040	E- 13	97027-06016	B- 3								
95027-08012	C- 15		B- 7								
95304-06700	C- 12	97027-06030	D- 12								

